



Submittal Sheet

Submitted for: Approval Record

Job Name: _____

Date: _____

Contractor: _____

Location: _____

Engineer: _____

Tag: _____

AIR-CON MULTI-SPLIT II

Indoor Units				Outdoor Unit
High-Wall	Cassette	Duct	Floor and Ceiling	
A16EW4H4R09				AMTCM4H4R24
A16EW4H4R12	A16EC4H4R12	A16EK4H4R12	A16EL4H4R12	AMTCM4H4R30
A16EW4H4R18	A16EC4H4R18	A16EK4H4R18	A16EL4H4R18	AMTCM4H4R36
	A16EC4H4R24	A16EK4H4R24	A16EL4H4R24	AMTCM4H4R42

Notes: _____

Summary, Features, and Construction Views

Indoor Units

- A16EW4H4R09
- A16EW4H4R12
- A16EW4H4R18

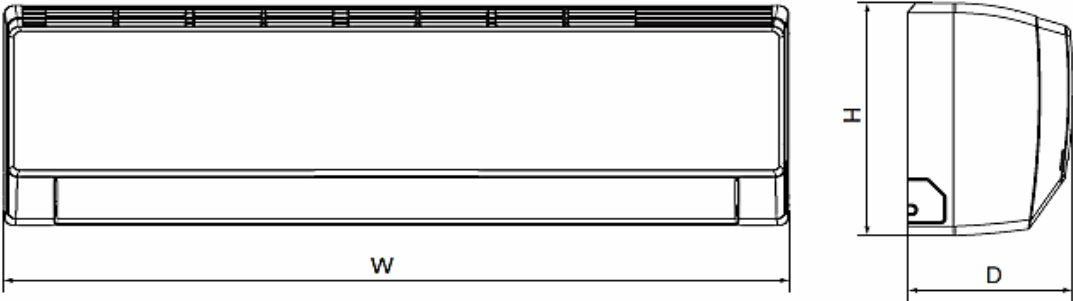

09 & 12K Indoor Units Wall Bracket:

18K Indoor Unit Wall Bracket:

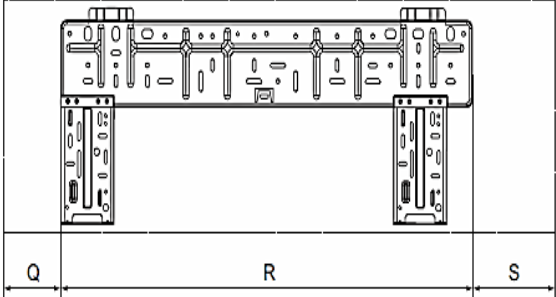
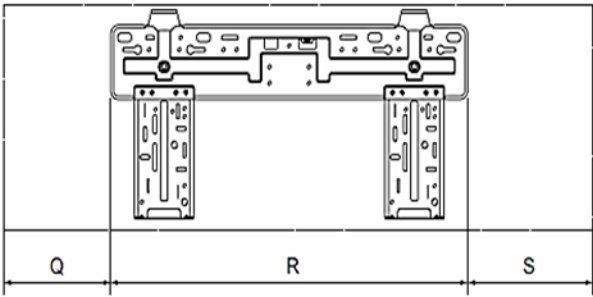

Unit: mm						
Model	W	H	D	Q	R	S
A16EW4H4R09	848	275	180	135	540	173
A16EW4H4R12						
A16EW4H4R18	940	298	200	108	694	138
Unit: Inches						
A16EW4H4R09	33-3/8	10-7/8	7-3/32	5-5/16	21-1/4	6-13/16
A16EW4H4R12						
A16EW4H4R18	37	11-3/4	7-7/8	4-1/4	27-11/32	5-7/16

*True dimensions in mm, dimensions in inches have been approximated to the nearest 32th of an inch

Summary, Features, and Construction Views

Remote Controller

YB1FAF(XFAN)

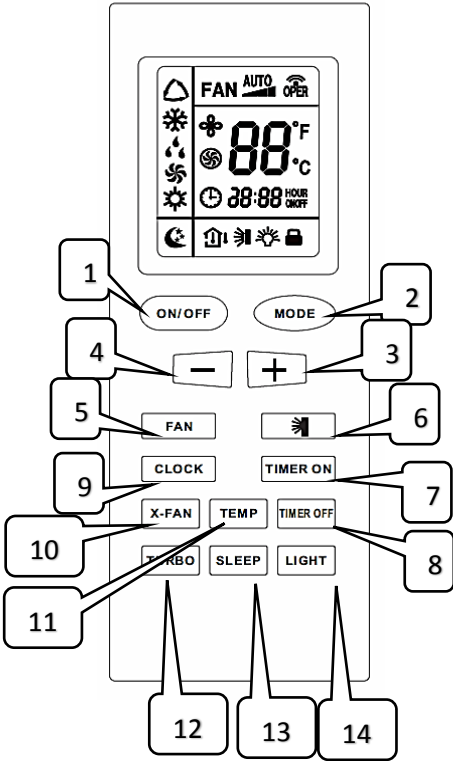

1	ON/OFF-Press to Start/Stop Operation
2	MODE-Press to select operation mode (AUTO/COOL/DRY/FAN/HEAT)
3	+ Press to increase temperature setting
4	- Press to decrease temperature setting
5	FAN-Press to set fan speed
6	☞ Press to set swing angle
7	TIMER ON-Press to set timer on
8	TIMER OFF-Press to set timer off
9	CLOCK-Press to set clock
10	X-FAN-(X-FAN is the alternative expression of BLOW for the purpose of understanding)
11	TEMP
12	TURBO
13	SLEEP
14	LIGHT-Press to turn on or off controller backlight

Specifications

Specifications

Indoor Unit High-Wall Type

Parameter	Unit	Value		
Model		A16EW4H4R09	A16EW4H4R12	A16EW4H4R18
Product Type		High-Wall	High-Wall	High-Wall
Rated Voltage	V~	208/230	208/230	208/230
Rated Frequency	Hz	60	60	60
Power Supply Mode		Outdoor	Outdoor	Outdoor
Cooling Capacity	Btu/h	9000	12000	18000
Heating Capacity	Btu/h	9800	13000	19800
Air Flow Volume (SH/H/M/L/SL)	m ³ /h	560/500/430/370/-	580/470/430/370/-	850/780/650/550/-
	CFM	329/294/253/217/-	341/276/253/217/-	500/459/382/323/-
Dehumidifying Volume	L/h	0.8	1.4	1.8
Application Area	m ²	12-18	16-24	23-24
	ft ²	129-193	172-258	247-258
Fan Type		Cross-flow	Cross-flow	Cross-flow
Diameter Length (DXL)	mm	Φ92X645	Φ92X645	Φ98X710
	in	Φ3.6X25.4	Φ3.6X25.4	Φ 3.8X27.9
Fan Motor Cooling Speed (SH/H/M/L/SL)	r/min	1260/1100/950/750/-	1280/1100/950/750/-	1350/1200/1050/900/-
Fan Motor Heating Speed (SH/H/M/L/SL)	r/min	1320/1200/1100/950/-	1300/1170/1050/950/-	1420/1250/1150/1050/-
Output of Fan Motor	W	20	20	20
Fan Motor RLA	A	0.2	0.2	0.25
Evaporator Form		Aluminum Fin-copper Tube	Aluminum Fin-copper Tube	Aluminum Fin-copper Tube
Pipe Diameter	mm	Φ7	Φ7	Φ7
	in	Φ0.27	Φ0.27	Φ0.27
Row-fin Gap	mm	2-1.4	2-1.4	2-1.4
	in	0.078-0.055	0.078-0.055	0.078-0.055
Coil Length (LXDXW)	mm	645X25.4X267	645X25.4X267	715X25.4X304.8
	in	25.4X1.0X10.5	25.4X1.0X10.5	28.1X1X12
Swing Motor Model		MP24AA	MP24AA	MP28VB
Output of Swing Motor	W	2.4	2.4	2
Fuse	A	3.15	3.15	3.15
Sound Pressure Level (SH/H/M/L/SL)	dB(A)	41/37/35/26/-	42/38/36/26/-	46/44/40/35/-
Sound Power Level (SH/H/M/L/SL)	dB(A)	51/47/45/36/-	52/48/46/36/-	56/54/50/45/-

Dimension (WXHxD)	mm	848X275X180	848X275X180	940X298X200
	in	33.4X10.8X7.0	33.4X10.8X7.0	37.0X11.7X7.8
Dimension of Carton Box (LXWXH)	mm	915X255X355	915X255X355	1010X285X380
	in	36.0X10.0X13.9	36.0X10.0X13.9	39.8X11.2X14.9
Dimension of Package (LXWXH)	mm	918X258X370	918X258X370	1013X288X395
	In	36.1X10.1X14.5	36.1X10.1X14.5	39.9X11.3X15.5
Net Weight	kg	10	10	13
	Lbs	22	22	28.7
Gross Weight	kg	13	13	17
	Lbs	28.7	28.7	37.5

Indoor Units

Cassette

A16EC4H4R12

A16EC4H4R18

A16EC4H4R24

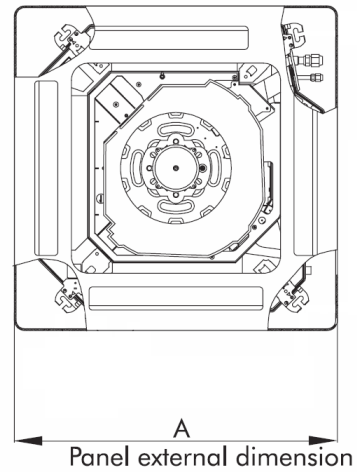
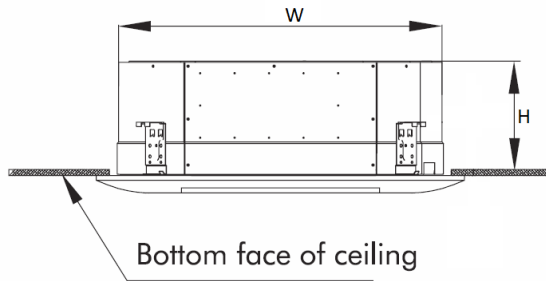

Unit: mm			
Model	W	H	A
A16EC4H4R12	570	230	650
A16EC4H4R18	570	230	650
A16EC4H4R24	840	240	950
Unit: Inches			
A16EC4H4R12	10.6	9.1	25.6
A16EC4H4R18	10.6	9.1	25.6
A16EC4H4R24	33.1	9.45	37.4

Indoor Unit Cassette Type

Parameter	Unit	Value		
Model		A16EC4H4R12	A16EC4H4R18	A16EC4H4R24
Product Type		Cassette	Cassette	Cassette
Rated Voltage	V~	208/230	208/230	208/230
Rated Frequency	Hz	60	60	60
Phases		1	1	1
Cross-sectional Power Cable		AWG18	AWG18	AWG18
Recommended Power Cable		4-Core Stranded Copper Wire	4-Core Stranded Copper Wire	4-Core Stranded Copper Wire
Fuse Current	A	3.15	3.15	3.15
Cooling Capacity	Btu/h	12000	14400	22800
Heating Capacity	Btu/h	13000	16000	27400
Air Flow Volume (SH/H/M/L/SL)	m ³ /h	600/500/450	600/500/450	/1180//950/850/
	CFM	353/294/265	353/294/265	/694//559/500/
Dehumidifying Volume	L/h	1.4	1.80	2.50
	Pint/h	2.96	3.80	5.28
Application Area	m ²	16-24	19-29	30-46
	ft ²	172-258	206-310	326-490
Fan Type		Centrifugal	Centrifugal	Centrifugal
Fan Quantity		1	1	1
Diameter-Height (DXL)	mm	Φ283-148	Φ283-148	Φ450-112
	in	Φ11.14-5.83	Φ11.14-5.83	Φ17.7-4.4
Fan Motor Model		FN11T-2	FN11T-2	FN35B-1
Fan Motor Drive Type		Direct Drive	Direct Drive	Direct Drive
Fan Motor Speed (SH/H/M/L/SL)	r/min	845/700/600	845/700/600	620/570/520
Standard Static Pressure	InWg	0.00	0.00	0.00
	psig	0.00	0.00	0.00
Output of Fan Motor	W	11	11	50
Input of Fan Motor	W	50	50	100
Fan Motor RLA	A	0.23	0.23	0.43
Fan Motor Capacitor	μF	1	1	3
Motor Full Load Amp (FLA)	A	0.18	0.18	0.43
Evaporator Material		Inner Groove Copper-Aluminum	Inner Groove Copper-Aluminum	Inner Groove Copper-Aluminum
Pipe Diameter	mm	Φ9.52	Φ9.52	Φ7
	in	Φ3/8	Φ3/8	Φ0.2756
Evaporator Face Area	m ²	0.19	0.19	0.35
	in ²	294	294	543
Evaporator Number of Rows		2	2	3

Evap. Tube Pitch (a) X Row Pitch (b)	mm	25.4X19.05	25.4X19.05	19.05X12.07
	in	1X3/4	1X3/4	3/4X0.475
Evaporator Fin Type		Hydrophilic film-louver fin	Hydrophilic film-louver fin	Hydrophilic film-louver fin
Evaporator Fin Color		Blue	Blue	Blue
Evap. Dimensions (LXHXW)	mm	956.1X203.2X38.1	956.1X203.2X38.1	2040.8X171.5X30
	in	37.6X8X1.5	37.6X8X1.5	80.35X6.75X1.18
Evap. Max Allowable Pressure	MPa	4.0	4.0	4.3
	PSI	580	580	623
Air Filter Size (LXW/No.)	mm	344.5X333.5/1	344.5X333.5/1	543X542/1
	in	13-5/16 X13-1/8 /1	13-5/16 X13-1/8 /1	21.38X21.34/1
Drain Connection (Outer Diameter)	mm	Φ31	Φ31	Φ31
	in	Φ1.22	Φ1.22	Φ1.22
Sound Pressure Level (SH/H/M/L/SL)	dB(A)	//46/44/42	//46/44/42	/39//37//35/
Sound Power Level (SH/H/M/L/SL)	dB(A)	//56/54/52	//56/54/52	/49//47//45/
Gas Pipe (to IDU)	mm	Φ9.52	Φ12.7	Φ15.9
	in	Φ3/8	Φ1/2	Φ5/8
Liquid Pipe (to IDU)	mm	Φ6.35	Φ6.35	Φ9.52
	in	Φ1/4	Φ1/4	Φ3/8
Connection Method		Flare Connection	Flare Connection	Flare Connection
Dimension (WDXDH)	mm	570X570X230	570X570X230	840X840X240
	in	10.6X10.6X9.1	10.6X10.6X9.1	33.1X33.1X9.45
Dimension of Carton Box (LXWXH)	mm	848X728X310	848X728X310	960X960X310
	in	33.4X28.7X12.2	33.4X28.7X12.2	37.8X37.8X12.2
Dimension of Package (LXWXH)	mm	851X731X325	851X731X325	963X963X325
	In	33.5X28.8X12.8	33.5X28.8X12.8	37.1X37.1X12.8
Net Weight	kg	18	18	28
	Lbs	40	40	62
Gross Weight	kg	23	23	35
	Lbs	51	51	77
Panel Outline Dimension (WDXDH)	mm	650X650X50	650X650X50	950X950X60
	in	25.6X25.6X2	25.6X25.6X2	37.4X37.4X2.4
Panel Dimensions of Carton (WxDxH)	mm	730X670X102	730X670X102	1040X1025X115
	in	28.7X26.4X4	28.7X26.4X4	40.9X40.4X4.5
Panel Package Dimension (LXWXH)	mm	733X673X117	733X673X117	1043X1028X130
	In	28.9X26.5X4.6	28.9X26.5X4.6	41.1X40.5X5.1
Panel Net Weight	kg	2.50	2.50	6.5
	Lbs	5.5	5.5	14.3
Panel Gross Weight	kg	3.65	3.65	10
	Lbs	8.1	8.1	22.1

Duct Type

A16EK4H4R12

A16EK4H4R18

A16EK4H4R24

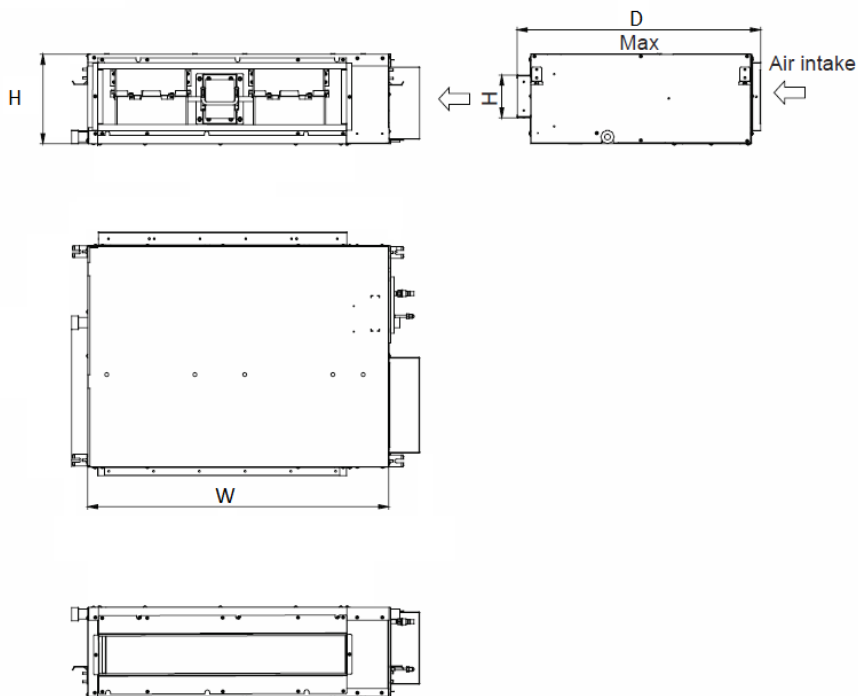

Unit: mm			
Model	W	D	H
A16EK4H4R12	700	615	200
A16EK4H4R18	900	615	200
A16EK4H4R24	1100	615	200
Unit: Inches			
A16EK4H4R12	27.56	24.21	7.87
A16EK4H4R18	35.4	24.21	7.87
A16EK4H4R24	43.3	24.21	7.87

Indoor Unit Duct Type

Parameter	Unit	Value		
Model		A16EK4H4R12	A16EK4H4R18	A16EK4H4R24
Product Type		Duct Type	Duct Type	Duct Type
Rated Voltage	V~	208/230	208/230	208/230
Rated Frequency	Hz	60	60	60
Phases		1	1	1
Cross-sectional Power Cable		AWG18	AWG18	AWG18
Recommended Power Cable		4-Core Stranded Copper Wire	4-Core Stranded Copper Wire	4-Core Stranded Copper Wire
Fuse Current	A	3.15	3.15	3.15
Cooling Capacity	Btu/h	11900	15300	23800
Heating Capacity	Btu/h	13100	18700	27400
Air Flow Volume (SH/H/M/L/SL)	m ³ /h	/550/400/300/	/700/600/500/	/1000/750/550/
	CFM	/324/235.4/177/	/411.95/353.1/294.25/	/588.5/441.4/323.7
Dehumidifying Volume	L/h	1.4	1.80	2.5
	Pint/h	2.96	3.80	5.28
Application Area	m ²	15.9-23.8	23.9-35.7	31.8-47.6
	ft ²	171-256	257-384	342-512
Fan Type		Centrifugal	Centrifugal	Centrifugal
Fan Quantity		2	3	4
Diameter-Height (DXL)	mm	Φ139.45-134.62	Φ139.45-134.62	Φ139.45-134.62
	in	Φ5.5-5.3	Φ5.5-5.3	Φ5.5-5.3
Fan Motor Model		FG40A	FG60A	FG20E
Fan Motor Drive Type		Direct Drive	Direct Drive	Direct Drive
Fan Motor Speed (SH/H/M/L/SL)	r/min	960/830/700	920/780/720	985/800/680
Output of Fan Motor	W	49	75	22.5
Input of Fan Motor	W	80	100	124
Fan Motor RLA	A	0.35	0.43	0.54
Fan Motor Capacitor	μF	3	3	3
Motor Full Load Amp (FLA)	A	0.31	0.41	0.50
Evaporator Material		Inner Groove Copper-Aluminum	Inner Groove Copper-Aluminum	Inner Groove Copper-Aluminum
Pipe Diameter	mm	Φ7	Φ7	Φ7
	in	Φ0.275	Φ0.275	Φ0.275
Evaporator Face Area	m ²	0.11	0.15	0.19
	in ²	170	232	295
Evaporator Number of Rows		3	3	3
Evap. Tube Pitch (a) X Row Pitch (b)	mm	19.05X12.7	19.05X12.7	19.05X12.7
	in	3/4X1/2	3/4X1/2	3/4X1/2

Evaporator Fin Type		Hydrophilic film-louver fin	Hydrophilic film-louver fin	Hydrophilic film-louver fin
Evaporator Fin Color		Blue	Blue	Blue
Evap. Dimensions (LXHXW)	mm	527X209.55X25.4	725X209.55X38.1	925X209.55X38.1
	in	20.75X8.25X1	28.5X8.25X1.5	36.4X8.25X1.5
Evap. Max Allowable Pressure	MPa	4.3	4.3	4.3
	PSI	623	623	623
Air Filter Size (LXW/No.)	mm	601.5X197.4/1	802X193/1	1002.6X196.5/1
	in	23.7X7.77/1	31.57X7.6/1	39.5X7.75/1
Drain Connection (Outer Diameter)	mm	26	26	26
	in	1.02	1.02	1.02
Sound Pressure Level (SH/H/M/L/SL)	dB(A)	/39/35/32/	/47/37/33/	/42/38/34/
Sound Power Level (SH/H/M/L/SL)	dB(A)	/49/45/42/	/51/47/43/	/52/48/44/
Gas Pipe (to IDU)	mm	Φ9.52	Φ12.7	Φ15.9
	in	Φ3/8	Φ1/2	Φ5/8
Liquid Pipe (to IDU)	mm	Φ6.35	Φ6.35	Φ9.52
	in	Φ1/4	Φ1/4	Φ3/8
Connection Method		Flare Connection	Flare Connection	Flare Connection
Dimension (WXDXH)	mm	700X615X200	900X615X200	1100X615X200
	in	27.56X24.21X7.87	35.4X24.2X7.9	43.3X24.2X7.9
Dimension of Carton Box (LXWXH)	mm	890X740X290	1120X740X290	1320X740X290
	in	35X30X11.8	44X29.1X11.4	51.9X29.1X11.4
Dimension of Package (LXWXH)	mm	893X743X305	1123X743X305	1323X743X305
	in	37X31X12.6	44.2X29.25X12	52X29.25X12
Net Weight	kg	23	27	31
	Lbs	51	60	68
Gross Weight	kg	29	36	41
	Lbs	64	79	90

Floor and Ceiling Type

A16EL4H4R12

A16EL4H4R18

A16EL4H4R24

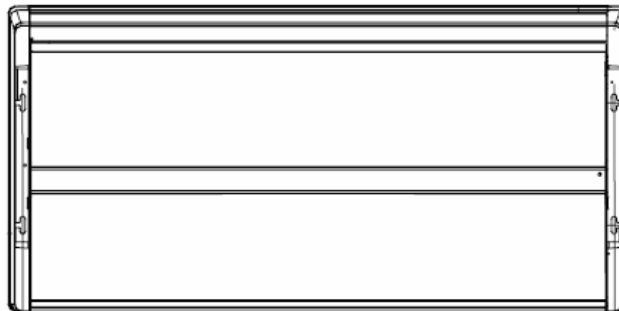
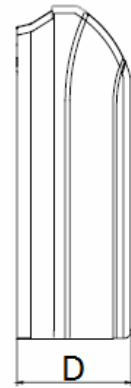
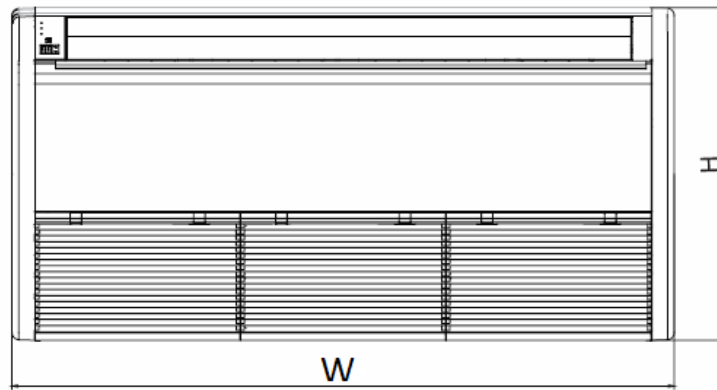

Unit: mm			
Model	W	D	H
A16EL4H4R12	1220	225	700
A16EL4H4R18	1220	225	700
A16EL4H4R24	1220	225	700
Unit: Inches			
A16EL4H4R12	48	8.9	27.6
A16EL4H4R18	48	8.9	27.6
A16EL4H4R24	48	8.9	27.6

Indoor Unit Floor and Ceiling Type

Parameter	Unit	Value		
Model		A16EL4H4R12	A16EL4H4R18	A16EL4H4R24
Product Type		Floor and Ceiling	Floor and Ceiling	Floor and Ceiling
Rated Voltage	V~	208/230	208/230	208/230
Rated Frequency	Hz	60	60	60
Phases		1	1	1
Cross-sectional Power Cable		AWG18	AWG18	AWG18
Recommended Power Cable		4-Core Stranded Copper Wire	4-Core Stranded Copper Wire	4-Core Stranded Copper Wire
Fuse Current	A	3.15	3.15	3.15
Cooling Capacity	Btu/h	11900	17000	22800
Heating Capacity	Btu/h	13100	18700	27400
Air Flow Volume (SH/H/M/L/SL)	m ³ /h	/650/550/450/	/950/700/500/	/1250/900/700/
	CFM	/383/324/265	/559/412/294	/736/530/412/
Dehumidifying Volume	L/h	1.40	1.80	2.50
	Pint/h	2.96	3.80	5.28
Application Area	m ²	15.9-23.8	23.9-35.7	31.8-47.6
	ft ²	171-256	257-384	342-512
Fan Type		Centrifugal	Centrifugal	Centrifugal
Fan Quantity		4	4	4
Diameter-Height (DXL)	mm	Φ139.5-104.8	Φ139.5-104.8	Φ139.5-104.8
	in	Φ5.5-4.125	Φ5.5-4.125	Φ5.5-4.125
Fan Motor Model		FG10A	FG20E	FG50A
Fan Motor Drive Type		Direct Drive	Direct Drive	Direct Drive
Fan Motor Speed (SH/H/M/L/SL)	r/min	/690/610/480/	/985/800/680/	/985/800/680/
Output of Fan Motor	W	15	20	40
Input of Fan Motor	W	55	110	145
Fan Motor RLA	A	0.28	0.56	0.63
Fan Motor Capacitor	μF	1	2.5	2
Motor Full Load Amp (FLA)	A	0.3	0.5	0.5
Evaporator Material		Inner Groove Copper-Aluminum	Inner Groove Copper-Aluminum	Inner Groove Copper-Aluminum
Pipe Diameter	mm	Φ7	Φ7	Φ7
	in	Φ0.275	Φ0.275	Φ0.275
Evaporator Face Area	m ²	0.24	0.28	0.28
	in ²	372	434	434
Evaporator Number of Rows		2	3	3
Evap. Tube Pitch (a) X Row Pitch (b)	mm	19.05X12.7	19.05X12.7	19.05X12.7
	in	3/4X1/2	3/4X1/2	3/4X1/2

Evaporator Fin Type		Hydrophilic film-louver fin	Hydrophilic film-louver fin	Hydrophilic film-louver fin
Evaporator Fin Color		Blue	Blue	Blue
Evap. Dimensions (LXHXW)	mm	804.9X304.8X25.4	920X304.8X50.8	920X304.8X50.8
	in	31.7X12X1	36.2X12X2	36.2X12X2
Evap. Max Allowable Pressure	MPa	4.3	4.3	4.3
	PSI	623	623	623
Air Filter Size (LXW/No.)	mm	554X220.5/2	554X220.5/2	554X220.5/2
	in	21.8X8.7/2	21.8X8.7/2	21.8X8.7/2
Drain Connection (Outer Diameter)	mm	Φ17	Φ17	Φ17
	in	Φ0.67	Φ0.67	Φ0.67
Sound Pressure Level (SH/H/M/L/SL)	dB(A)	/40/38/36/	/45/42/40/	/48/46/44/
Sound Power Level (SH/H/M/L/SL)	dB(A)	/50/48/46/	/55/52/50/	/58/56/54/
Gas Pipe (to IDU)	mm	Φ9.52	Φ12.7	Φ15.9
	in	Φ3/8	Φ1/2	Φ5/8
Liquid Pipe (to IDU)	mm	Φ6.35	Φ6.35	Φ9.52
	in	Φ1/4	Φ1/4	Φ3/8
Connection Method		Flare Connection	Flare Connection	Flare Connection
Dimension (WXHXD)	mm	1220X700X225	1220X700X225	1220X700X225
	in	48X27.6X8.9	48X27.6X8.9	48X27.6X8.9
Dimension of Carton Box (LXHXW)	mm	1340X820X300	1340X820X300	1340X820X300
	in	52.75X32.3X11.8	52.75X32.3X11.8	52.75X32.3X11.8
Dimension of Package (LXHXW)	mm	1343X823X315	1343X823X315	1343X823X315
	in	52.9X32.4X12.4	52.9X32.4X12.4	52.9X32.4X12.4
Net Weight	kg	40	40	45
	Lbs	88	88	99
Gross Weight	kg	50	50	54
	Lbs	110	110	119

Summary, Features, and Construction Views

Outdoor Unit

AMTCM4H4R18, AMTCM4H4R24, AMTCM4H4R30

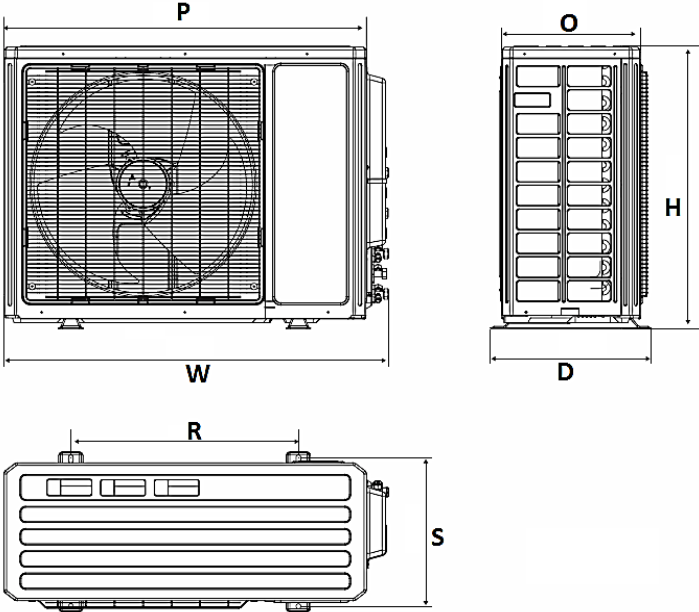

AMTCM4H4R42

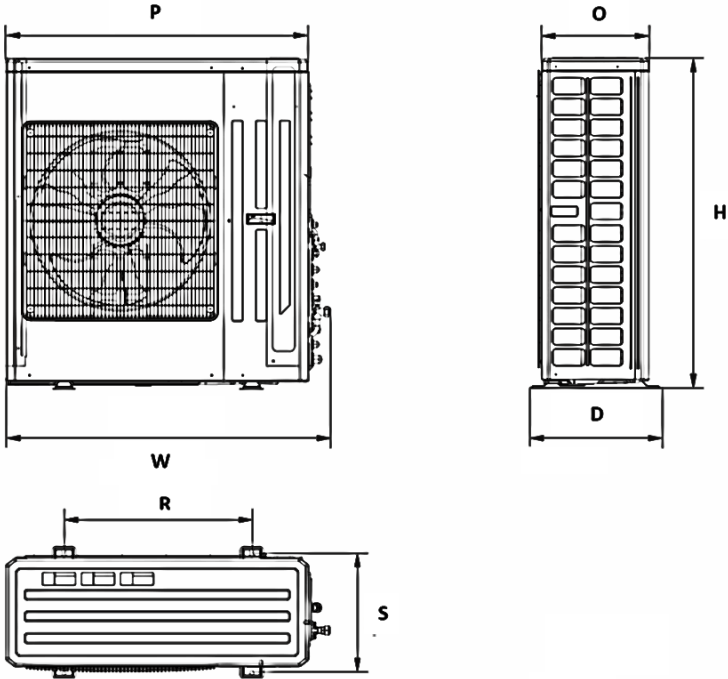

Unit: mm							
Model	W	H	D	O	P	R	S
AMTCM4H4R18	965	700	498	341	892	559	368
AMTCM4H4R24	980	790	440	341	892	559	368
AMTCM4H4R30	976	787	440	370	920	559	400
AMTCM4H4R36	1080	1103	440	362	1016	630	376
AMTCM4H4R42	1068	1093	432	356	1016	611	383
Unit: Inches							
AMTCM4H4R18	38	27-9/16	19-39/64	13-27/64	35-1/8	22	14-1/2
AMTCM4H4R24	38-37/64	31-7/64	17-21/64	13-27/64	35-1/8	22	14-1/2
AMTCM4H4R30	38-27/64	31	17-21/64	14-37/64	36-7/32	24	15-23/32
AMTCM4H4R36	42-1/2	43-27/64	17-21/64	14-1/4	40	24-13/16	14-51/64
AMTCM4H4R42	42-1/32	43-1/64	17-1/64	14-1/64	40	24-1/16	15-1/16

*True dimensions in mm, dimensions in inches have been approximated to the nearest 32th of an inch

Outdoor Unit

Parameter		Unit	Value	
Model			AMTCM4H4R18	AMTCM4H4R24
Product Code			CB228W07700	CB228W07800
Power Supply	Rated Voltage	V~	208/230	208/230
	Rated Frequency	Hz	60	60
	Phases		1	1
Power Supply Mode			Outdoor	Outdoor
Power Cable			AWG14 3 Core	AWG12 3 Core
Circuit Breaker		A	25	30
Cooling Capacity (Min~Max)		Btu/h	18000(6998~21001)	24000(7500~33000)
Heating Capacity (Min~Max)		Btu/h	19000(7000~22600)	26000(7500~35000)
Cooling Power Input		W	1440	1920
Heating Power Input		W	1520	2050
Rate Power Input		W	2800	4550
Cooling Current Input		A	6.26	8.35
Heating Current Input		A	6.61	8.90
Rated Current Input		A	12.42	20.19
Starting Current		A	5	5
EER		W/W	3.66	3.66
		(Btu/h)/W	12.50	12.50
COP		W/W	3.66	3.72
		(Btu/h)/W	12.50	12.70
SEER			22	21
HSPF			10.5	10.50
Outdoor Unit	Compressor Manufacturer		Zhuhai Landa Compressor Co.	Zhuhai Landa Compressor Co.
	Compressor Model		QXA-B141zF030A	QXAS-D23zX090B
	Compressor Oil		RB68EP	RB68EP
	Compressor Oil Charge	L	0.39	0.95
	Compressor Type		Inverter Rotary	Inverter Rotary
	L.R.A.	A	/	/
	Compressor RLA	A	10.82	15.82
	Compressor Power Input	W	1440	2550
	Overload Protector		1NT11L-6233	1NT11L-6233
	Electrical Heater Power Input	W	96+/-5%	160+/-5%
	Throttling Method		Electronic Expansion Valve	Electronic Expansion Valve
	Ambient Temperature (Cooling)	°C	-18~48	-18~48
		°F	0~118	0~118
	Ambient Temperature (Heating)	°C	-20~24	-20~24
		°F	-4~75	-4~75
	Condenser Form		Aluminum Fin-copper Tube	Aluminum Fin-copper Tube
Max Drive IDU		2	3	

Pipe diameter (Gas) IU 1	mm	Φ9.52	Φ9.52
	in	Φ3/8	Φ3/8
Pipe diameter (Gas) IU 2	mm	Φ9.52	Φ9.52
	in	Φ3/8	Φ3/8
Pipe diameter (Gas) IU 3	mm	-	Φ9.52
	in	-	Φ3/8
Pipe diameter (Liquid) IU 1	mm	Φ6.35	Φ6.35
	in	Φ1/4	Φ1/4
Pipe diameter (Liquid) IU 2	mm	Φ6.35	Φ6.35
	in	Φ1/4	Φ1/4
Pipe diameter (Liquid) IU 3	mm	-	Φ6.35
	in	-	Φ1/4
Fan Motor Model		LW60M-ZL	LW92K-ZL
Fan Motor Speed	RPM	630	800
Output of Fan Motor	W	60	90
Fan Motor Capacitor	μF	/	3.5
Air Flow Volume of Outdoor Unit	m ³ /h	3200	4000
	CFM	1883	2354
Fan Type		Axial-Flow	Axial-flow
Fan Diameter-height	mm	Φ520-58	Φ550-66
	in	Φ20.5-2 ¼	Φ21.7-2.62
Defrosting Method		Automatic Defrosting	Automatic Defrosting
Climate Type		T1	T1
Isolation		I	I
Moisture Protection		IPX4	IPX4
Permissible Excessive Operating Pressure for the Discharge Side	MPa	4.3	4.3
	PSI	623	625
Permissible Excessive Operating Pressure for the Suction Side	MPa	2.5	2.5
	PSI	362	365
Sound Pressure Level (H/M/L)	dB(A)	56/-/-	59/-/-
Sound Power Level (H/M/L)	dB(A)	63/-/-	69/-/-
Dimension (WXHXD)	mm	955X700X396	980X790X427
	in	37.6X27.6X15.6	38.6X31.1X16.8
Dimension of Carton Box (L/W/H)	mm	1026X455X735	1080X485X840
	in	40.4X17.9X28.9	42.5X19.1X33.1
Dimension of Package (L/W/H)	mm	1029X458X750	1083X488X855
	in	40.5X18.0X29.5	42.6X19.2X33.7
Net Weight	kg	52	69.5
	Lbs	115	153
Gross Weight	kg	56.5	74.5
	Lbs	125	164
Refrigerant		R410A	R410A

	Refrigerant Charge	kg	1.6	2.2
		Lbs	3.5	4.85
Connection Pipe	Not Additional Gas Length	m	10	30
		ft	32.8	98
	Gas Additional Charge	g/m	20	20
		Oz/ft	0.215	0.215
	Max Distance Height (indoor to indoor)	m	10	10
		ft	32.8	33
	Max Distance Height (indoor to outdoor with indoor up)	m	10	10
		ft	32.8	32.8
	Max Distance Height (indoor to outdoor with outdoor up)	m	10	10
		ft	32.8	32.8
	Max. Equivalent pipe length (outdoor to last indoor)	m	10	20
		ft	32.8	65
	Max Distance Length (total)	m	20	60
		ft	65.6	197

Parameter		Unit	Value		
Model			AMTCM4H4R30	AMTCM4H4R36	AMTCM4H4R42
Product Code			CB228W07900	CB228W08000	CN860W0180
Power Supply	Rated Voltage	V~	208/230	208/230	208/230
	Rated Frequency	Hz	60	60	60
	Phases		1	1	1
Power Supply Mode			Outdoor	Outdoor	Outdoor
Power Cable			AWG12 3 Core	AWG12 3 Core	AWG10 3 Core
Circuit Breaker		A	30	35	40
Cooling Capacity (Min~Max)		Btu/h	28400(8189~33438)	34000(8871~35826)	39000(8871~40944)
Heating Capacity (Min~Max)		Btu/h	30000(8189~32414)	42500(8871~44356)	45004(8871~46062)
Cooling Power Input		W	2270	2720	3740
Heating Power Input		W	2350	3370	3650
Rate Power Input		W	3800	3800	4000
Cooling Current Input		A	9.87	11.84	16.5
Heating Current Input		A	10.22	14.64	16
Rated Current Input		A	16.86	16.86	/
Starting Current		A	/	/	/
EER	W/W		3.66	3.66	3.06
	(Btu/h)/W		12.50	12.50	10.43
COP	W/W		3.74	3.70	3.61
	(Btu/h)/W		12.76	12.62	12.33
SEER			21	21	21
HSPF			10.5	10.50	10.2

Outdoor Unit	Compressor Manufacturer		Zhuhai Landa Compressor Co.	Zhuhai Landa Compressor Co.	Zhuhai Landa Compressor Co.
	Compressor Model		QXAS-D32zX090A	QXAS-D32zX090A	QXAS-D32zX090A
	Compressor Oil		FV50S	FV50S	FV50S
	Compressor Oil Charge	L	1	1	1
	Compressor Type		Inverter Rotary	Inverter Rotary	Inverter Rotary
	L.R.A.	A	/	/	/
	Compressor RLA	A	13.9	15.6	17.8
	Compressor Power Input	W	4150	4150	4150
	Overload Protector		1NT11L-6233	1NT11L-6233	1NT11L-6233
	Electrical Heater Power Input	W	96+/-5%	96+/-5%	96+/-5%
	Throttling Method		Electronic Expansion Valve	Electronic Expansion Valve	Electronic Expansion Valve
	Ambient Temperature (Cooling)	°C	-18~48	-18~48	-18~48
		°F	0~118	0~118	0~118
	Ambient Temperature (Heating)	°C	-20~30	-20~30	-20~30
		°F	-4~86	-4~86	-4~86
	Condenser Form		Aluminum Fin-copper Tube	Aluminum Fin-copper Tube	Aluminum Fin-copper Tube
	Max Drive IDU		4	5	5
	Pipe diameter (Gas) IU 1	mm	Φ9.52	Φ9.52	Φ9.52
		in	Φ3/8	Φ3/8	Φ3/8
	Pipe diameter (Gas) IU 2	mm	Φ9.52	Φ9.52	Φ9.52
		in	Φ3/8	Φ3/8	Φ3/8
	Pipe diameter (Gas) IU 3	mm	Φ9.52	Φ9.52	Φ9.52
		in	Φ3/8	Φ3/8	Φ3/8
	Pipe diameter (Gas) IU 4	mm	Φ9.52	Φ9.52	Φ9.52
		in	Φ3/8	Φ3/8	Φ3/8
	Pipe diameter (Gas) IU 5	mm	-	Φ9.52	Φ9.52
		in	-	Φ3/8	Φ3/8
Pipe diameter (Liquid) IU 1	mm	Φ6.35	Φ6.35	Φ6.35	
	in	Φ1/4	Φ1/4	Φ1/4	
Pipe diameter (Liquid) IU 2	mm	Φ6.35	Φ6.35	Φ6.35	
	in	Φ1/4	Φ1/4	Φ1/4	
Pipe diameter (Liquid) IU 3	mm	Φ6.35	Φ6.35	Φ6.35	
	in	Φ1/4	Φ1/4	Φ1/4	

Pipe diameter (Liquid) IU 4	mm	Φ6.35	Φ6.35	Φ6.35
	in	Φ1/4	Φ1/4	Φ1/4
Pipe diameter (Liquid) IU 5	mm	-	Φ6.35	Φ6.35
	in	-	Φ1/4	Φ1/4
Fan Motor Model		SWZ150A	SWZ150B	SWZ150B
Fan Motor Speed	RPM	850	880	880
Output of Fan Motor	W	100	170	170
Fan Motor Capacitor	μF	/	/	/
Air Flow Volume of Outdoor Unit	m ³ /h	4000	7700	7700
	CFM	2354	4531	4531
Fan Type		Axial-Flow	Axial-flow	Axial-flow
Fan Diameter-height	mm	Φ550-120	Φ570-152	Φ570-152
	in	Φ21.7-4.75	Φ22.4-6	Φ22.4-6
Defrosting Method		Automatic Defrosting	Automatic Defrosting	Automatic Defrosting
Climate Type		T1	T1	T1
Isolation		I	I	I
Moisture Protection		IPX4	IPX4	IP44
Permissible Excessive Operating Pressure for the Discharge Side	MPa	4.2	4.2	4.2
	PSI	609	609	609
Permissible Excessive Operating Pressure for the Suction Side	MPa	2.5	2.5	2.5
	PSI	363	363	363
Sound Pressure Level (H/M/L)	dB(A)	59/-/-	61/-/-	61/-/-
Sound Power Level (H/M/L)	dB(A)	69/-/-	71/-/-	71/-/-
Dimension (WXHXD)	mm	980X790X427	1087X1103X440	1087X1103X440
	in	38.6X31.1X16.8	42.8X43.4X17.3	42.8X43.4X17.3
Dimension of Carton Box (L/W/H)	mm	1080X485X840	1155X480X1115	1155X480X1115
	in	42.5X19.1X33.1	45.5X18.9X43.9	45.5X18.9X43.9
Dimension of Package	mm	1083X488X855	1158X493X1235	1158X493X1235
	in	42.6X19.2X33.7	45.6X19.4X48.6	45.6X19.4X48.6

	(L/W/H)				
	Net Weight	kg	70	90	90
		Lbs	154	198	198
	Gross Weight	kg	77	98	98
		Lbs	170	216	216
	Refrigerant		R410A	R410A	R410A
	Refrigerant Charge	kg	2.8	3.65	3.65
		Lbs	6.2	8	8
Connection Pipe	Not Additional Gas Length	m	40	40	40
		ft	131	131	131
	Gas Additional Charge	g/m	20	20	20
		Oz/ft	0.215	0.215	0.215
	Max Distance Height (indoor to indoor)	m	7.5	7.5	7.5
		ft	24.6	24.6	24.6
	Max Distance Height (indoor to outdoor with indoor up)	m	15	15	15
		ft	49.2	49.2	49.2
	Max Distance Height (indoor to outdoor with outdoor up)	m	15	15	15
		ft	49.2	49.2	49.2
	Max. Equivalent pipe length (outdoor to last indoor)	m	25	25	25
		ft	82	82	82
	Max Distance Length (total)	m	70	75	75
		ft	230	246	246

Certified Units Combinations

Outdoor Unit	AHRI Certified Ref.	Indoor Unit	Cooling Capacity	Heating Capacity (Btuh @ 47°F)	EER	SEER	HSPF
AMTCM4H4R18	10149864	Non-Ducted Indoor Units	18000	19000	12.5	22	11
	10149865	Ducted Indoor Units	18000	19000	11.5	16	8.5
	10149866	Mixed (Ducted & Non-Ducted)	18000	19000	12	19	9.75
AMTCM4H4R24	10149867	Non-Ducted Indoor Units	24000	26000	12.5	21	11
	10149868	Ducted Indoor Units	24000	26000	10.5	16	8.5
	10149869	Mixed (Ducted & Non-Ducted)	24000	26000	11.5	18.5	9.75
AMTCM4H4R30	10149870	Non-Ducted Indoor Units	28400	30000	12.5	21	11.5
	10149871	Ducted Indoor Units	28400	30000	10.5	16	8.5
	10149872	Mixed (Ducted & Non-Ducted)	28400	30000	11.5	18.5	10
AMTCM4H4R36	10149873	Non-Ducted Indoor Units	34000	42500	12.5	21	11.5
	10149874	Ducted Indoor Units	34000	42500	11.5	16	8.5
	10149875	Mixed (Ducted & Non-Ducted)	34000	42500	12	18.5	10
AMTCM4H4R42	10149876	Non-Ducted Indoor Units	39000	45000	10.4	21	10.2
	10149877	Ducted Indoor Units	39500	46500	9.8	14.7	9.6
	10149878	Mixed (Ducted & Non-Ducted)	39250	45750	10.1	17.85	9.9