

Job Name:	
Submitted By:	



**Submittal Sheet For:** YN024GMFI22RPE / CB024GMFILD FHE

Date \_\_\_\_\_  
 Ref. \_\_\_\_\_

**Ceiling Recessed Inverter Driven Heat Pump (2 Ton)**

System Full Set Model: **CYB024GMFILCBD**  
 AHRI Reference Number: **208191864**

**Cooling Mode Performance**

Rated Cooling	24000 BTU/hr
Ambient Range	5°F ~ 122°F
SEER Rating	20.7 BTU/W·h
EER Rating	12.5 BTU/W·h

\* 100% Capacity @ Indoor DB 80°F/WB 66°F / Outdoor DB 95°F/WB 75°F / m.w. 16"/lineset

**Heating Mode Performance**

Rated Heating	25000 BTU/hr
Ambient Range	-13°F ~ 86°F
HSPF IV (V)	10.5 (8.5) BTU/W·h
COP	3.26 W/W

\* High Heat (47°F) = 25000 BTU / Low Heat (17°F) = 19000 BTU / COP(5°F) = 1.75



Ceiling-Cassette Indoor Unit



Outdoor Condensing Unit



Installation Kit (Pipe+ Cable)



Handheld Remote Controller

**Electrical Information**

Rated Input (W)	Cooling	Heating
	1,920	2,210
Rated Current (A)	8.78	10.0
Breaker Needed	25A (double-pole)	
Power Supply	208~230V, 1Ph, 60Hz	

**Piping and Refrigerant**

Liquid Line (OD)	3/8"
Suction Line (OD)	5/8"
Refrigerant Precharge	R410a (10 - 25 ft.)
Max Length/Height Diff.	164 Ft. / 82 Ft.

**Interior Unit (Air Handler) Specifications**

Airflow Rate (CFM)	706 (Hi) / 635 (Med) / 547 (Lo)
Sound Level (dBA)	49.0 (Hi) / 46.0 (Med) / 43.0 (Lo)
Auto Air Circulation	8-Way Louver (4 Sides + 4 Corners)
Dimensions (WDH)	32"-5/8 x 32"-5/8 x 8"-1/8
Weight (Lbs)	47.2 (Handler) / 13.2 (Decorative Panel)

**Exterior Unit (Condenser) Specifications**

Airflow Rate (CFM)	2,235
Sound Level (dBA)	61.0
Metering Device	Electronic Expansion Valve (EXV)
Compressor	Twin-Rotary
Dimensions (WDH)	37"-1/4 x 16"-1/8 x 31"-7/8"
Weight (Lbs)	124.8

This combination is Energy-Star® certified.



# CB024GMFILDFHE Air Handler Dimensional Data

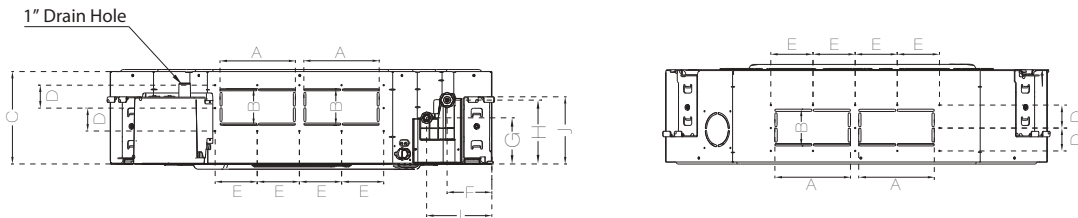

A	B	C	D	E	F	G	H	I	J
165 mm	80 mm	205 mm	50 mm	92 mm	98 mm	101 mm	139 mm	142 mm	146 mm
6-1/2 in.	3-1/8 in.	8-1/16 in.	2 in.	3-5/8 in.	3-7/8 in.	4 in.	5-1/2 in.	5-9/16 in.	5-3/4 in.

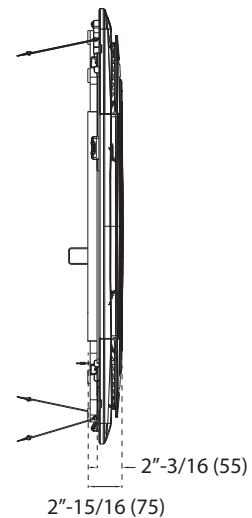
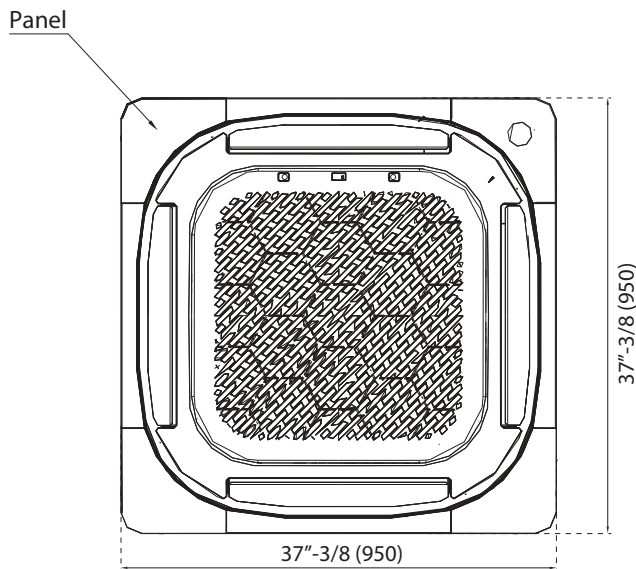
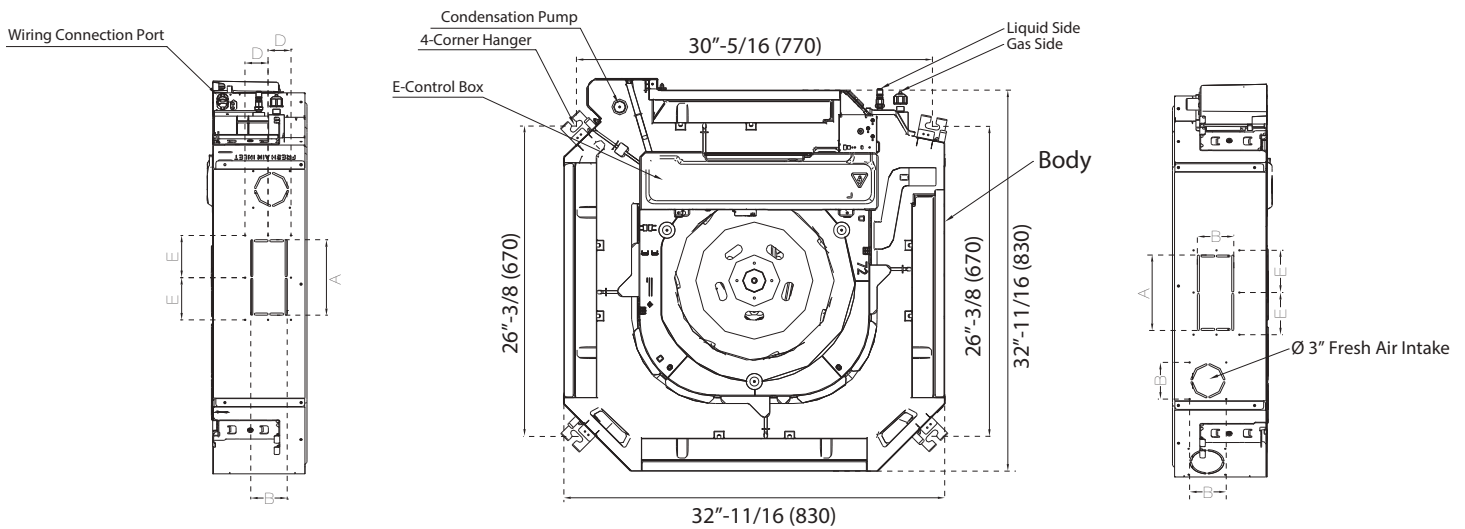

All dimensions are in Inches (mm)

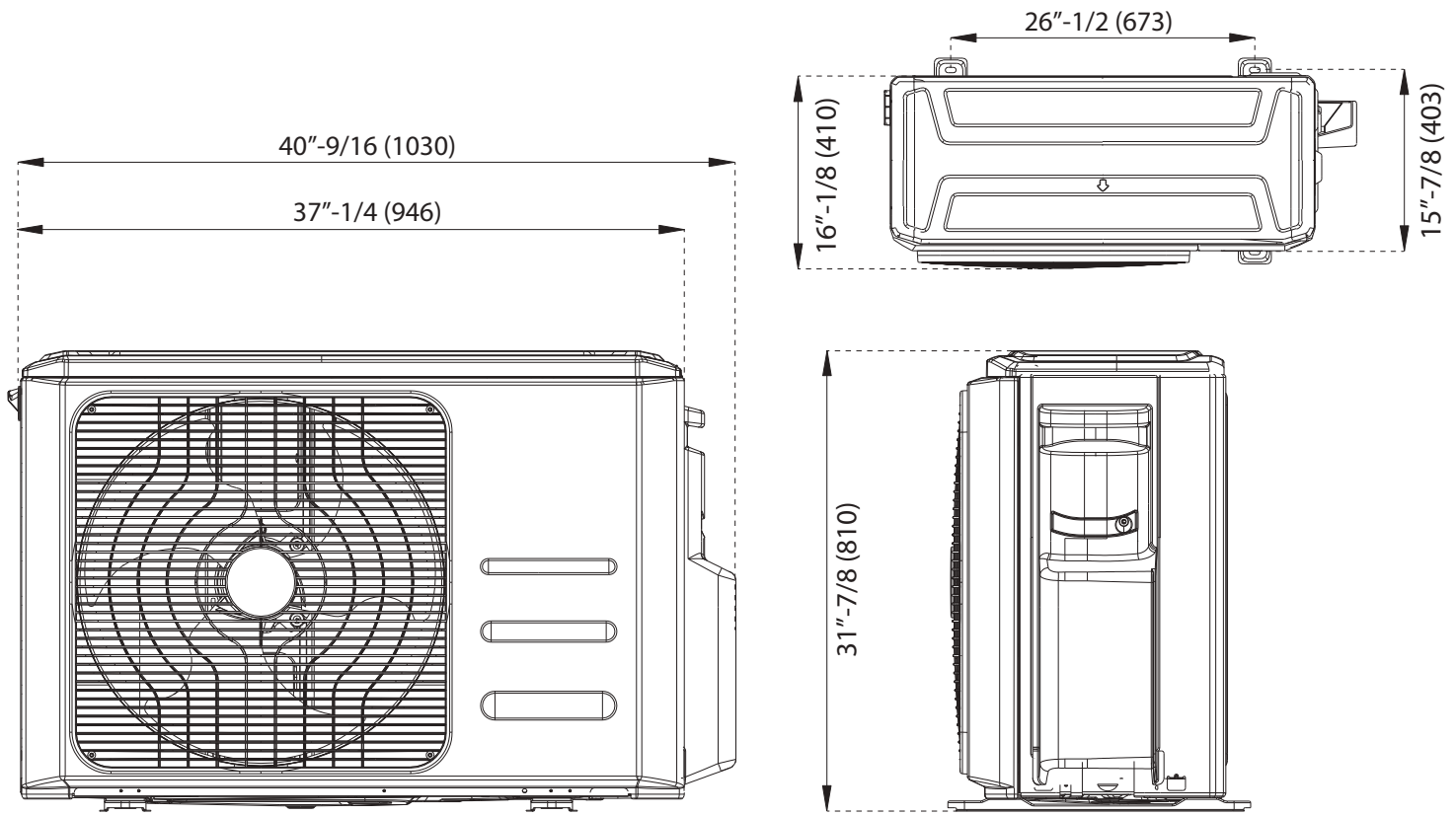

### Warranty Information and Length



Complete warranty details are available with the vendor or online at <https://www.pdhvac.com/support/warranty/>. This high quality system is eligible for up to **5** years limited warranty on the compressor, and **5** years on other internal parts. To qualify for this warranty, the system must be installed within 90 days and registered properly. All other installations that are unregistered qualify for only **1** year parts/compressor warranty.

### Outstanding Features

- Compact Design
- Fire-Proof Controller Box
- Optional Fresh Air Intake
- Reserved Air Outlet for Duct
- 360° Omni-directional Airflow
- Built-In Condensate Drain Pump
- Decorative Panel/Grille (Included)
- Optional Programmable Controller

### Available Accessories

Part Number	Description
IKT-LCVR4P-KIT	<i>Decorative PVC Line Cover Kit</i>
TST-LCACWIFIKP	<i>Smart-WiFi Wired Wall Thermostat Kit</i>
BRK-FRM-C-2P	<i>Folding Mounting Bracket w/ Leveler</i>
IKT-UVL32UL-AG	<i>UVC Bacterial Disinfection Kit</i>
@ICM517	<i>Ultimate Surge and Power Protection</i>