

Job Name:	
Submitted By:	



Submittal Sheet For: YN048GMFI18RUE / CB048GMFILD FHE

Date _____
 Ref. _____

Ceiling Recessed Inverter Driven Heat Pump (4 Ton)

System Full Set Model: **CYB048GMFILCBD**
 AHRI Reference Number: **208121949**

Cooling Mode Performance

Rated Cooling	48000 BTU/hr
Ambient Range	5°F ~ 122°F
SEER Rating	17.8 BTU/W·h
EER Rating	9.5 BTU/W·h

*100% Capacity @ Indoor DB 80°F/WB 66°F / Outdoor DB 95°F/WB 75°F / m.w. 16'lineset

Heating Mode Performance

Rated Heating	50000 BTU/hr
Ambient Range	5°F ~ 86°F
HSPF IV (V)	11.5 (8.8) BTU/W·h
COP	3.10 W/W

*High Heat (47°F) = 50000 BTU / Low Heat (17°F) = 30000 BTU / Capacities are Net



Ceiling-Cassette Indoor Unit



Outdoor Condensing Unit



Installation Kit (Pipe+Cable)



Handheld Remote Controller

Electrical Information

Rated Input (W)	Cooling	Heating
	5,050	4,730
Rated Current (A)	23.1	21.5
Breaker Needed	40A (double-pole)	
Power Supply	208~230V, 1Ph, 60Hz	

Piping and Refrigerant

Liquid Line (OD)	3/8"
Suction Line (OD)	5/8"
Refrigerant Precharge	R410a (10 - 25 ft.)
Max Length/Height Diff.	213 Ft. / 100 Ft.

This combination is AHRI+ETL certified.



Interior Unit (Air Handler) Specifications

Airflow Rate (CFM)	1,171 (Hi) / 1,059 (Med) / 935 (Lo)
Sound Level (dBA)	55.0 (Hi) / 53.0 (Med) / 50.0 (Lo)
Auto Air Circulation	8-Way Louver (4 Sides + 4 Corners)
Dimensions (WDH)	32"-5/8 x 32"-5/8 x 11"-3/8
Weight (Lbs)	64.6 (Handler) / 13.2 (Decorative Panel)

Exterior Unit (Condenser) Specifications

Airflow Rate (CFM)	4,500
Sound Level (dBA)	65.0
Metering Device	Electronic Expansion Valve (EXV)
Compressor	Rotary
Dimensions (WDH)	37"-1/2 x 16"-3/8 x 52"-1/2"
Weight (Lbs)	219.1

CB036GMFILDFHE Air Handler Dimensional Data

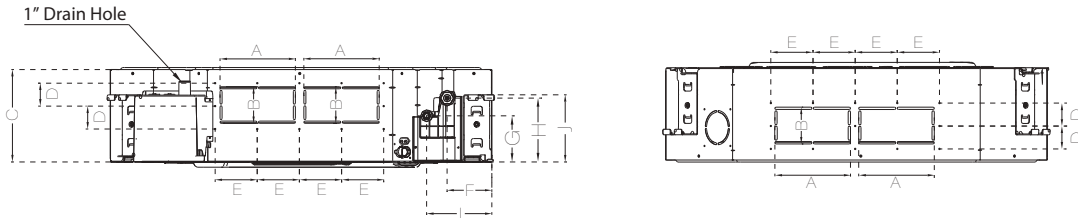

A	B	C	D	E	F	G	H	I	J
165 mm	100 mm	287 mm	60 mm	92 mm	98 mm	101 mm	139 mm	142 mm	146 mm
6-1/2 in.	3-15/16 in.	11-5/16 in.	2-3/8 in.	3-5/8 in.	3-7/8 in.	4 in.	5-1/2 in.	5-9/16 in.	5-3/4 in.

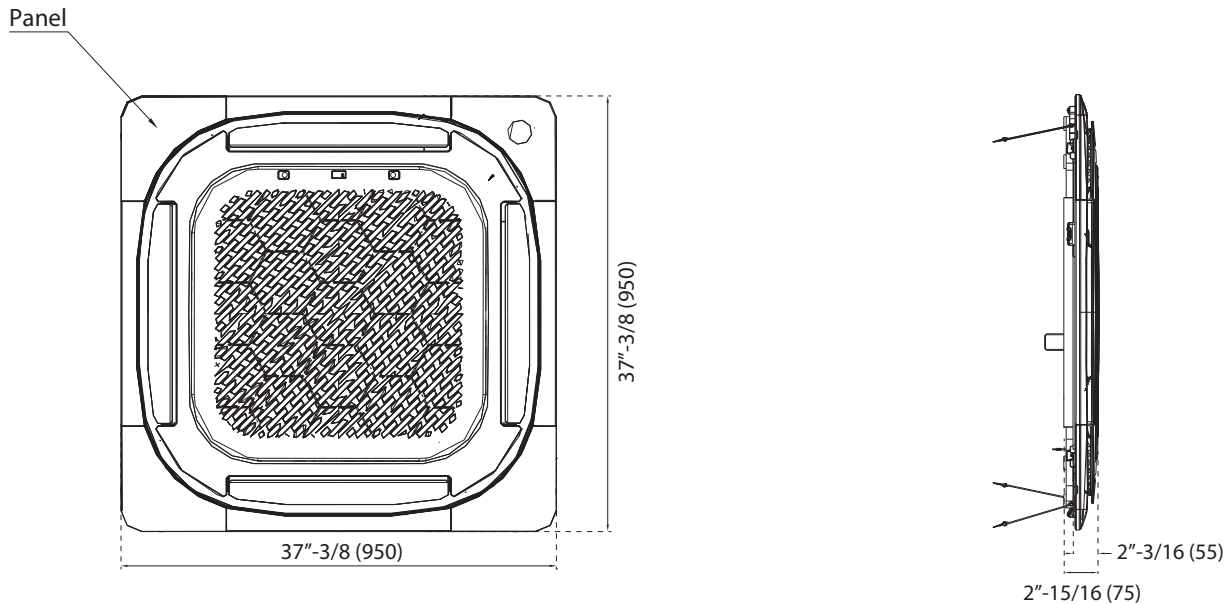
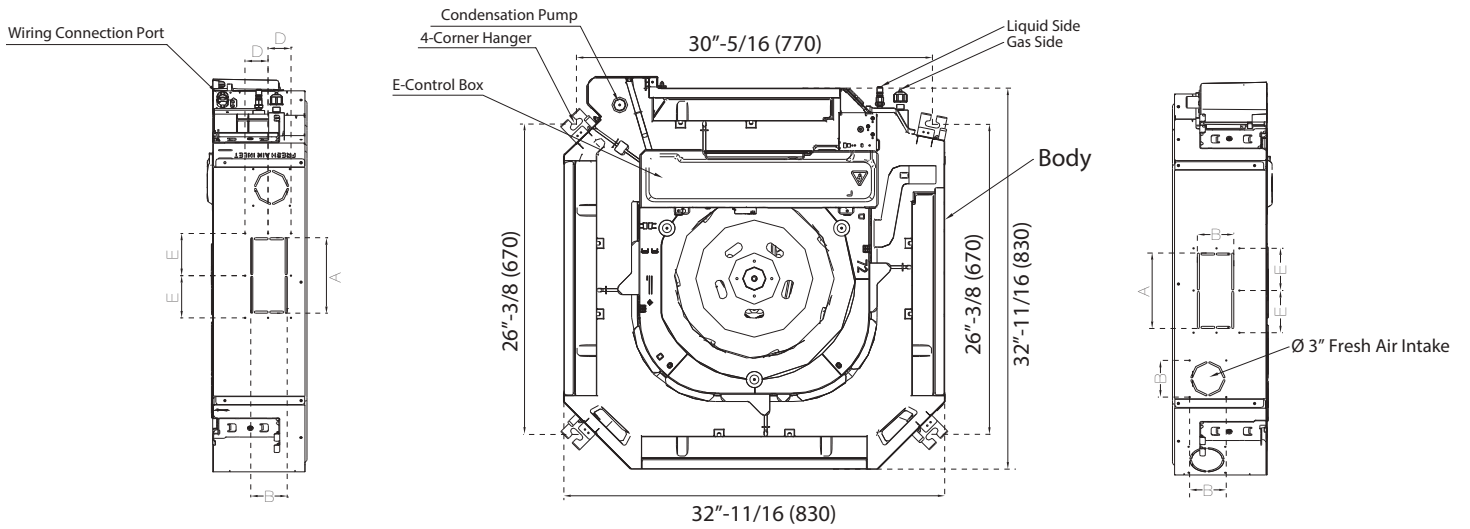

All dimensions are in Inches (mm)

FRONT VIEW

SIDE VIEW

TOP VIEW

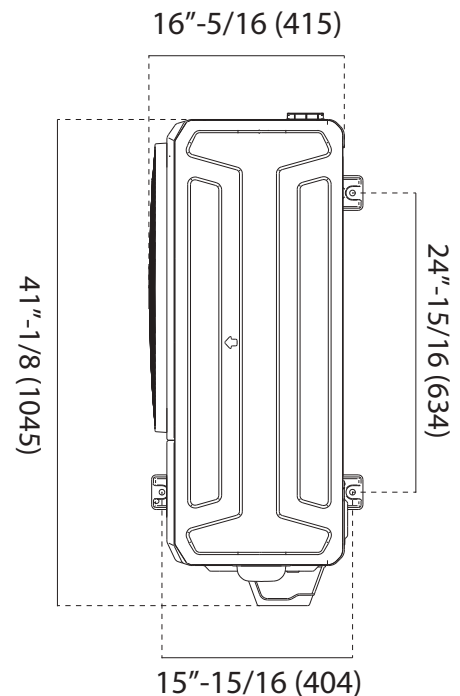
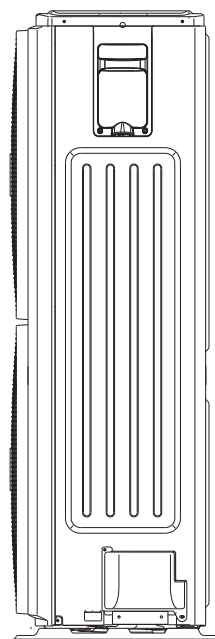
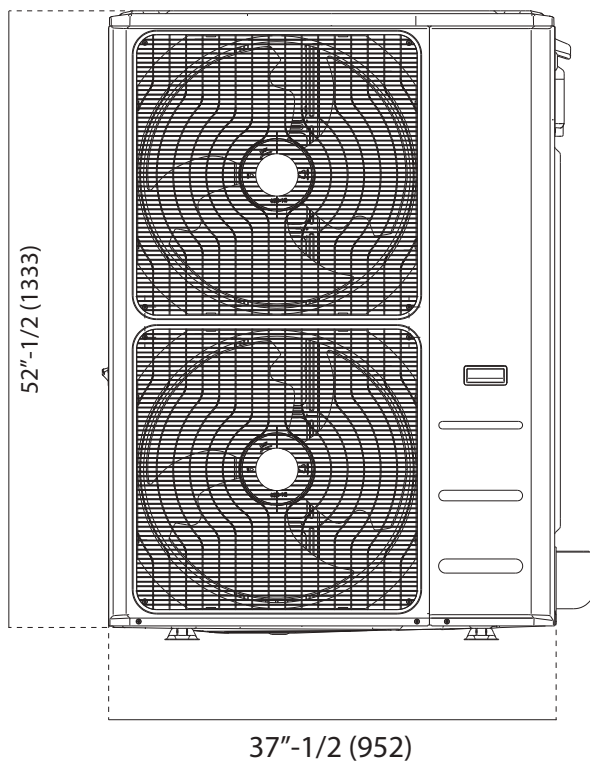

All dimensions are in Inches (mm)

Warranty Information and Length



Complete warranty details are available with the vendor or online at <https://www.pdhvac.com/support/warranty/>. This high quality system is eligible for up to **5** years limited warranty on the compressor, and **5** years on other internal parts. To qualify for this warranty, the system must be installed within 90 days and registered properly. All other installations that are unregistered qualify for only **1** year parts/compressor warranty.

Outstanding Features

- Compact Design
- Fire-Proof Controller Box
- Optional Fresh Air Intake
- Reserved Air Outlet for Duct
- 360° Omni-directional Airflow
- Built-In Condensate Drain Pump
- Decorative Panel/Grille (Included)
- Optional Programmable Controller

Available Accessories

Part Number	Description
IKT-LCVR4P-KIT	Decorative PVC Line Cover Kit
TST-LCACWIFIKP	Smart-WiFi Wired Wall Thermostat Kit
BRK-FRM-C-2P	Folding Mounting Bracket w/ Leveler
IKT-UVL32UL-AG	UVC Bacterial Disinfection Kit
@ICM517	Ultimate Surge and Power Protection