

Job Name:	
Submitted By:	



Submittal Sheet For: **YN018GMFI22RPE / RB018GMFILD FHD**

Date _____
 Ref. _____

Slim-Duct Concealed Inverter Heat Pump (1.5 Ton)

System Full Set Model: **RYB018GMFILDAD**
 AHRI Reference Number: **208141953**

Cooling Mode Performance

Rated Cooling	18000 BTU/hr
Ambient Range	5°F ~ 122°F
SEER Rating	20.5 BTU/W·h
EER Rating	12.5 BTU/W·h

* 100% Capacity @ Indoor DB 80°F/WB 66°F / Outdoor DB 95°F/WB 75°F / m.w. 25' lineset

Heating Mode Performance

Rated Heating	20000 BTU/hr
Ambient Range	-13°F ~ 86°F
HSPF IV (V)	11.0 (9.0) BTU/W·h
COP	3.12 W/W

* High Heat (47°F) = 20000 BTU / Low Heat (17°F) = 12000 BTU / COP(5°F) = 1.75

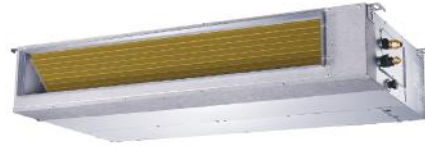

Slim Concealed Ducted Indoor Unit



Outdoor Condensing Unit



Installation Kit (Pipe+ Cable)



Wired Controller + Remote

Electrical Information

Rated Input (W)	Cooling	Heating
	1,455	1,880
Rated Current (A)	6.17	7.90
Breaker Needed	20A (double-pole)	
Power Supply	208~230V, 1Ph, 60Hz	

Piping and Refrigerant

Liquid Line (OD)	1/4"
Suction Line (OD)	1/2"
Refrigerant Precharge	R410a (10 - 25 ft.)
Max Length/Height Diff.	100 Ft. / 33 Ft.

Interior Unit (Air Handler) Specifications

Airflow Rate (CFM)	529 (Hi) / 450 (Med) / 371 (Lo)
Sound Level (dBA)	42.0 (Hi) / 38.0 (Med) / 35.5 (Lo)
ESP (Range)	0.0~0.4 in. wg. (0~100 Pa)
Dimensions (WDH)	34"-5/8 x 26"-1/2 x 8"-1/4
Weight (Lbs)	55.3

Exterior Unit (Condenser) Specifications

Airflow Rate (CFM)	2,058
Sound Level (dBA)	59.0
Metering Device	Electronic Expansion Valve (EXV)
Compressor	Rotary
Dimensions (WDH)	35" x 13"-1/2 x 26-1/2"
Weight (Lbs)	94.4

This combination is Energy-Star® certified.



RB018GMFILDFHD Air Handler Dimensional Data



Air Filter (optional) Air Inlet from Rear Side

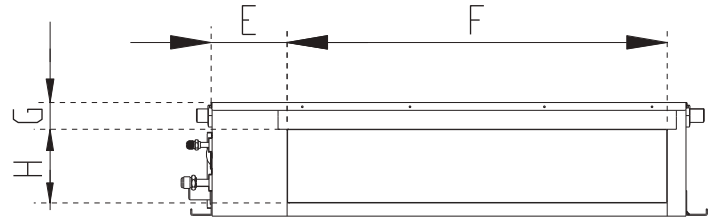
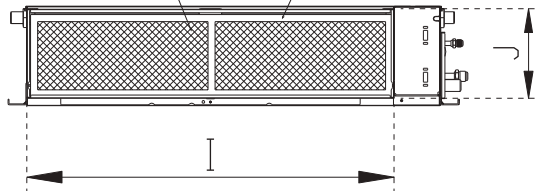

4-Corner Hanger
Electronic Control Box

Ø 1" Drain Pipe
Gas Side
Liquid Side

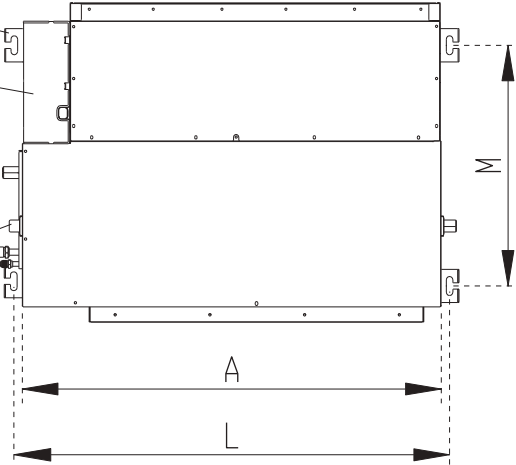

Test Mouth and Test Cover

Ø 1" Drain Connecting Pipe (for pump)

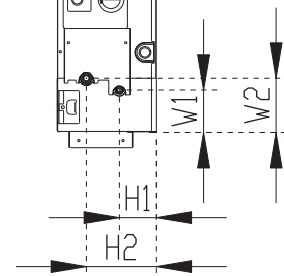

Air Filter (optional) Air Inlet from Bottom Side

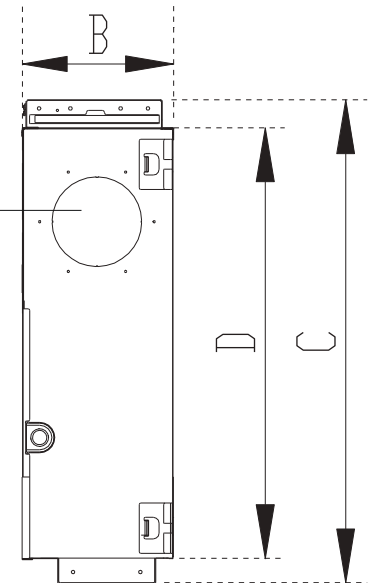
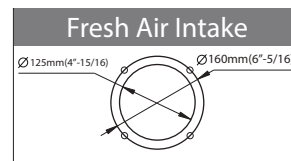
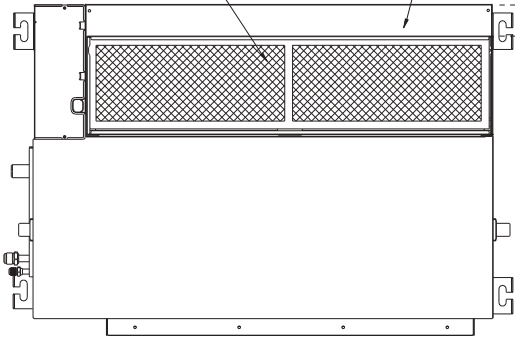

A	B	C	D	E	F	G	H
880 mm	210 mm	674 mm	600 mm	140 mm	706 mm	50 mm	136 mm
34-5/8 in.	8-1/4 in.	26-9/16 in.	23-5/8 in.	5-1/2 in.	27-13/16 in.	2 in.	5-3/8 in.

I	J	K	L	M	H1	H2	W1	W2
782 mm	190 mm	40 mm	920 mm	508 mm	78 mm	148 mm	88 mm	112 mm
30-13/16 in.	7-1/2 in.	1-9/16 in.	36-1/4 in.	20 in.	3-1/16 in.	5-13/16 in.	3-7/16 in.	4-7/16 in.

All dimensions are in Inches (mm)

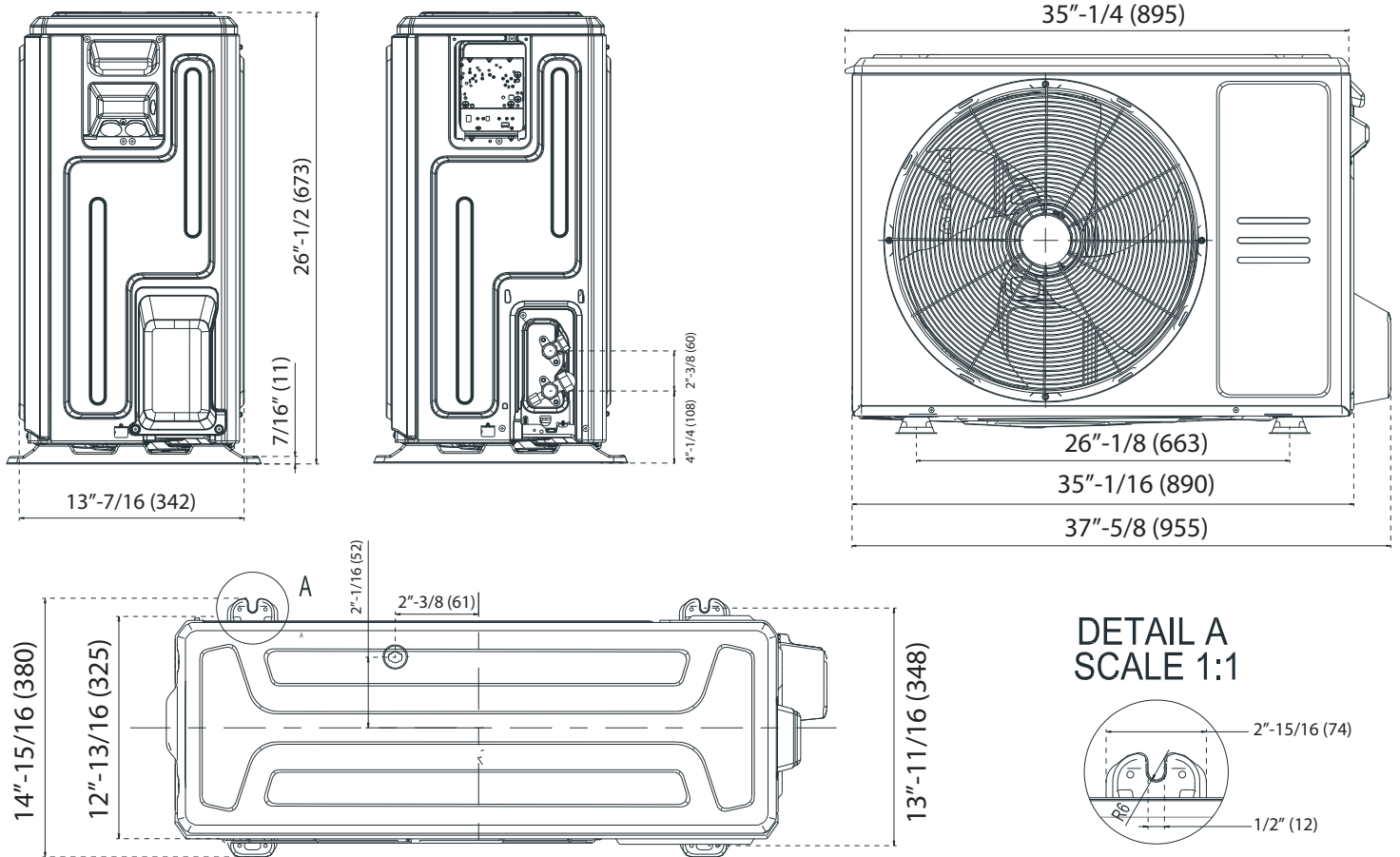

Warranty Information and Length



Complete warranty details are available with the vendor or online at <https://www.pdhvac.com/support/warranty/>. This high quality system is eligible for up to **5** years limited warranty on the compressor, and **5** years on other internal parts. To qualify for this warranty, the system must be installed within 90 days and registered properly. All other installations that are unregistered qualify for only **1** year parts/compressor warranty.

Outstanding Features

- Easy Clean Filter
- Flexible Air Intake
- High Static Pressure
- Eccentric Fan Design
- Slim Cabinet Footprint
- Built-In Condensate Drain Pump
- Horizontal or Vertical Installation
- Optional Programmable Controller

Available Accessories

Part Number	Description
IKT-LCVR4P-KIT	Decorative PVC Line Cover Kit
TST-LCACWIFIKP	Smart-WiFi Wired Wall Thermostat Kit
BRK-FRM-C-2P	Folding Mounting Bracket w/ Leveler
IKT-UVL32UL-AG	UVC Bacterial Disinfection Kit
@ICM517	Ultimate Surge and Power Protection