

Job Name:	
Submitted By:	



**Submittal Sheet For:** YN036GMFI18RUE / RB036GMFILDFHD

Date \_\_\_\_\_  
 Ref. \_\_\_\_\_

**Slim-Duct Concealed Inverter Heat Pump (3 Ton)**

System Full Set Model: **RYB036GMFILDBD**  
 AHRI Reference Number: **208121954**

**Cooling Mode Performance**

Rated Cooling	36000 BTU/hr
Ambient Range	5°F ~ 122°F
SEER Rating	16.7 BTU/W·h
EER Rating	9.0 BTU/W·h

\* 100% Capacity @ Indoor DB 80°F/WB 64°F / Outdoor DB 95°F/WB 75°F / m.w. 25' lineset

**Heating Mode Performance**

Rated Heating	40000 BTU/hr
Ambient Range	5°F ~ 86°F
HSPF IV (V)	11.5 (9.5) BTU/W·h
COP	3.37 W/W

\* High Heat (47°F) = 40000 BTU / Low Heat (17°F) = 25000 BTU / Capacities are Net

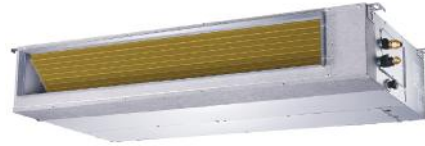

Slim Concealed Ducted Indoor Unit



Outdoor Condensing Unit



Installation Kit (Pipe+Cable)



Wired Controller + Remote

**Electrical Information**

Rated Input (W)	Cooling	Heating
	4,000	3,478
Rated Current (A)	18.3	15.9
Breaker Needed	40A (double-pole)	
Power Supply	208~230V, 1Ph, 60Hz	

**Piping and Refrigerant**

Liquid Line (OD)	3/8"
Suction Line (OD)	5/8"
Refrigerant Precharge	R410a (10 - 25 ft.)
Max Length/Height Diff.	213 Ft. / 100 Ft.

This combination is AHRI+ETL certified.



**Interior Unit (Air Handler) Specifications**

Airflow Rate (CFM)	1,082 (Hi) / 912 (Med) / 703 (Lo)
Sound Level (dBA)	48.0 (Hi) / 43.5 (Med) / 40.5 (Lo)
ESP (Range)	0.0~0.64 in. wg. (0~160 Pa)
Dimensions (WDH)	53"-1/2 x 30"-1/2 x 9"-3/4
Weight (Lbs)	110.9

**Exterior Unit (Condenser) Specifications**

Airflow Rate (CFM)	3,000
Sound Level (dBA)	63.5
Metering Device	Electronic Expansion Valve (EXV)
Compressor	Rotary
Dimensions (WDH)	37"-1/4 x 16"-1/8 x 31"-7/8"
Weight (Lbs)	155.4

# RB036GMFILDFHD Air Handler Dimensional Data



Air Filter (optional)      Air Inlet from Rear Side

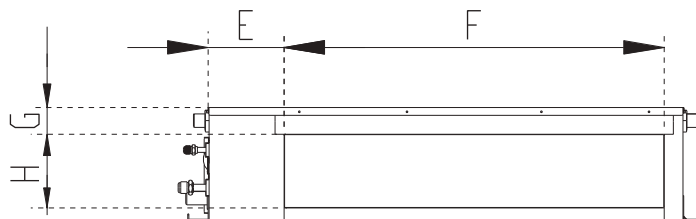
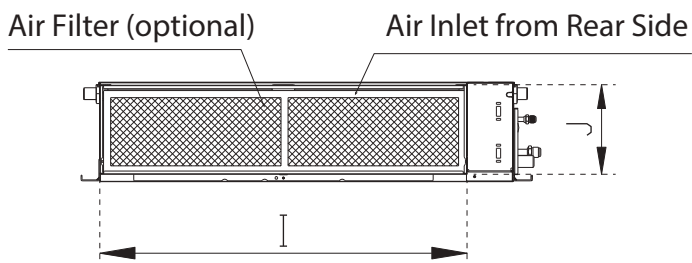

4-Corner Hanger

Electronic Control Box

Ø 1" Drain Pipe

Gas Side

Liquid Side

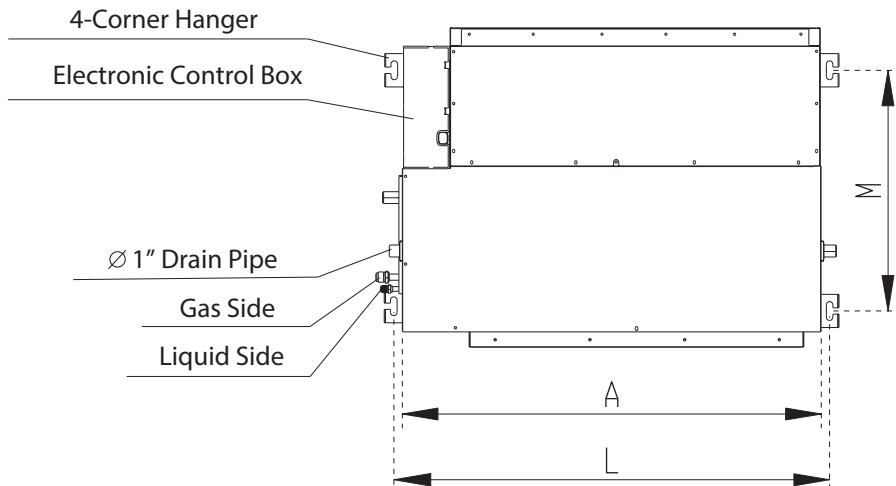

Test Mouth and Test Cover

Ø 1" Drain Connecting Pipe (for pump)

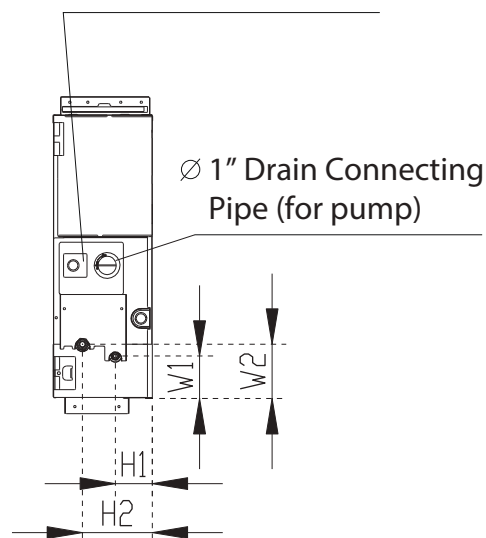

Air Filter (optional)

Air Inlet from Bottom Side

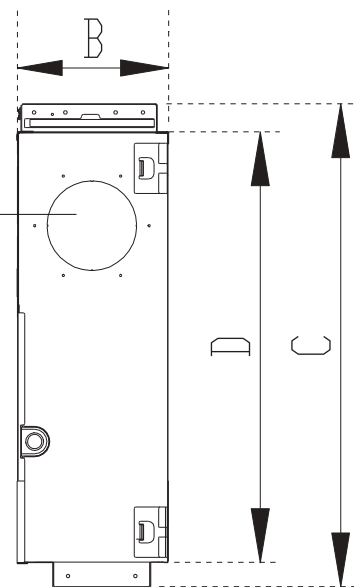
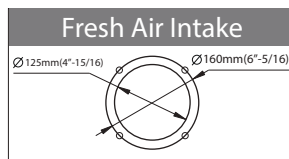
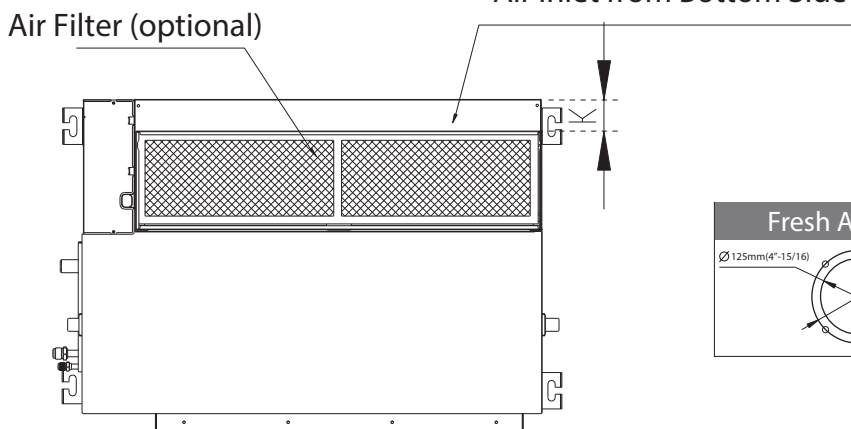

A	B	C	D	E	F	G	H
1360 mm	249 mm	774 mm	700 mm	140 mm	1186 mm	50 mm	175 mm
53-9/16 in.	9-13/16 in.	30-1/2 in.	27-9/16 in.	5-1/2 in.	46-11/16 in.	2 in.	6-7/8 in.

I	J	K	L	M	H1	H2	W1	W2
1261 mm	228 mm	5 mm	1400 mm	598 mm	80 mm	150 mm	130 mm	155 mm
49-5/8 in.	9 in.	3/16 in.	55-1/8 in.	23-9/16 in.	3-1/8 in.	5-15/16 in.	5-1/8 in.	6-1/8 in.

All dimensions are in Inches (mm)

All dimensions are in Inches (mm)

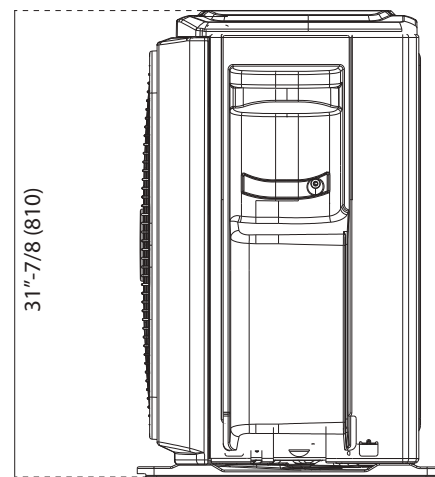
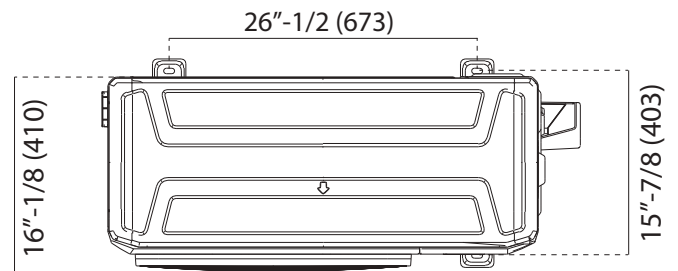
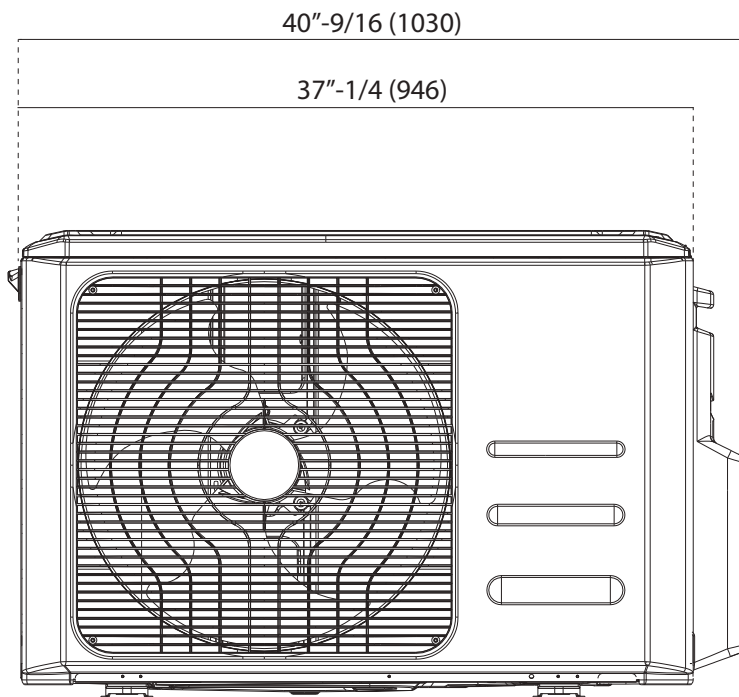

### Warranty Information and Length



Complete warranty details are available with the vendor or online at <https://www.pdhvac.com/support/warranty/>. This high quality system is eligible for up to **5** years limited warranty on the compressor, and **5** years on other internal parts. To qualify for this warranty, the system must be installed within 90 days and registered properly. All other installations that are unregistered qualify for only **1** year parts/compressor warranty.

### Outstanding Features

- Easy Clean Filter
- Flexible Air Intake
- High Static Pressure
- Eccentric Fan Design
- Slim Cabinet Footprint
- Built-In Condensate Drain Pump
- Horizontal or Vertical Installation
- Optional Programmable Controller

### Available Accessories

Part Number	Description
IKT-LCVR4P-KIT	<i>Decorative PVC Line Cover Kit</i>
TST-LCACWIFIKP	<i>Smart-WiFi Wired Wall Thermostat Kit</i>
BRK-FRM-C-2P	<i>Folding Mounting Bracket w/ Leveler</i>
IKT-UVL32UL-AG	<i>UVC Bacterial Disinfection Kit</i>
@ICM517	<i>Ultimate Surge and Power Protection</i>