

Job Name:	
Submitted By:	



Submittal Sheet For: YN036GMFI18RUE / UB036GMFILCFHD

Date _____
 Ref. _____

Floor/Ceiling Mount Inverter Driven Heat Pump (3 Ton)

System Full Set Model: **UYB036GMFILCBD**
 AHRI Reference Number: **208121959**

Cooling Mode Performance

Rated Cooling	36000 BTU/hr
Ambient Range	5°F ~ 122°F
SEER Rating	17.0 BTU/W·h
EER Rating	8.0 BTU/W·h

* 100% Capacity @ Indoor DB 80°F/WB 66°F / Outdoor DB 95°F/WB 75°F / m.w. 16'lineset

Heating Mode Performance

Rated Heating	38000 BTU/hr
Ambient Range	5°F ~ 86°F
HSPF IV (V)	10.0 (8.7) BTU/W·h
COP	2.80 W/W

* High Heat (47°F) = 38000 BTU / Low Heat (17°F) = 23000 BTU / Capacities are Net



Floor/Ceiling Flex Indoor Unit



Outdoor Condensing Unit



Installation Kit (Pipe+Cable)



Handheld Remote Controller

Electrical Information

Rated Input (W)	Cooling	Heating
	4,509	3,978
Rated Current (A)	20.6	18.2
Breaker Needed	40A (double-pole)	
Power Supply	208~230V, 1Ph, 60Hz	

Piping and Refrigerant

Liquid Line (OD)	3/8"
Suction Line (OD)	5/8"
Refrigerant Precharge	R410a (10 - 25 ft.)
Max Length/Height Diff.	213 Ft. / 100 Ft.

This combination is AHRI+ETL certified.



Interior Unit (Air Handler) Specifications

Airflow Rate (CFM)	1,036 (Hi) / 917 (Med) / 638 (Lo)
Sound Level (dBA)	51.5 (Hi) / 48.0 (Med) / 40.5 (Lo)
Mounting Options	Upright (Floor) / Horizontal (Ceiling)
Dimensions (WDH)	50"-5/8 x 9"-1/4 x 26"-9/16
Weight (Lbs)	69.0

Exterior Unit (Condenser) Specifications

Airflow Rate (CFM)	3,000
Sound Level (dBA)	63.5
Metering Device	Electronic Expansion Valve (EXV)
Compressor	Rotary
Dimensions (WDH)	37"-1/4 x 16"-1/8 x 31"-7/8"
Weight (Lbs)	155.4

UB036GMFILCFHD Air Handler Dimensional Data

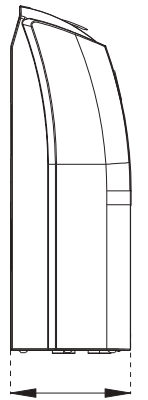
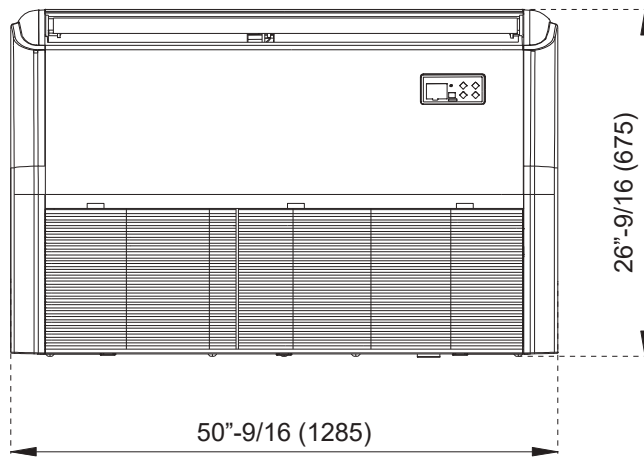
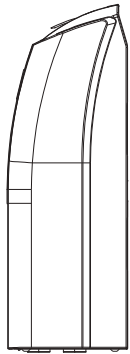
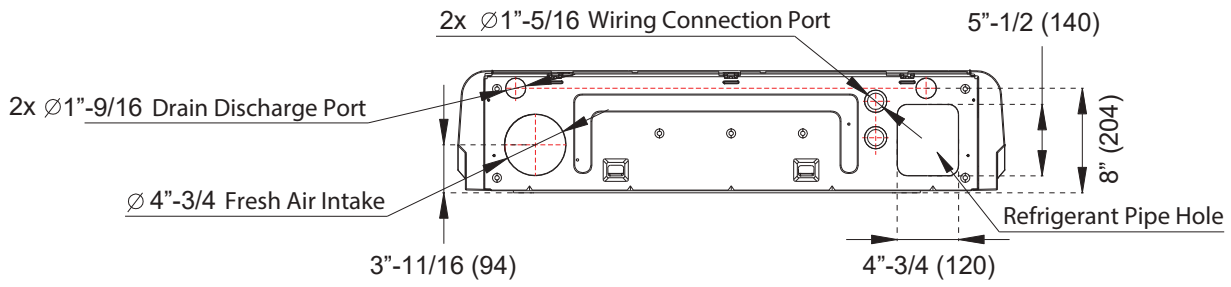

9''-1/4 (235)

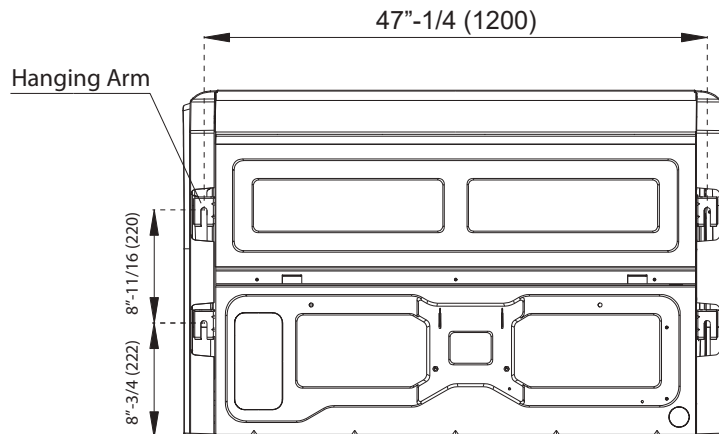

All dimensions are in Inches (mm)

All dimensions are in Inches (mm)

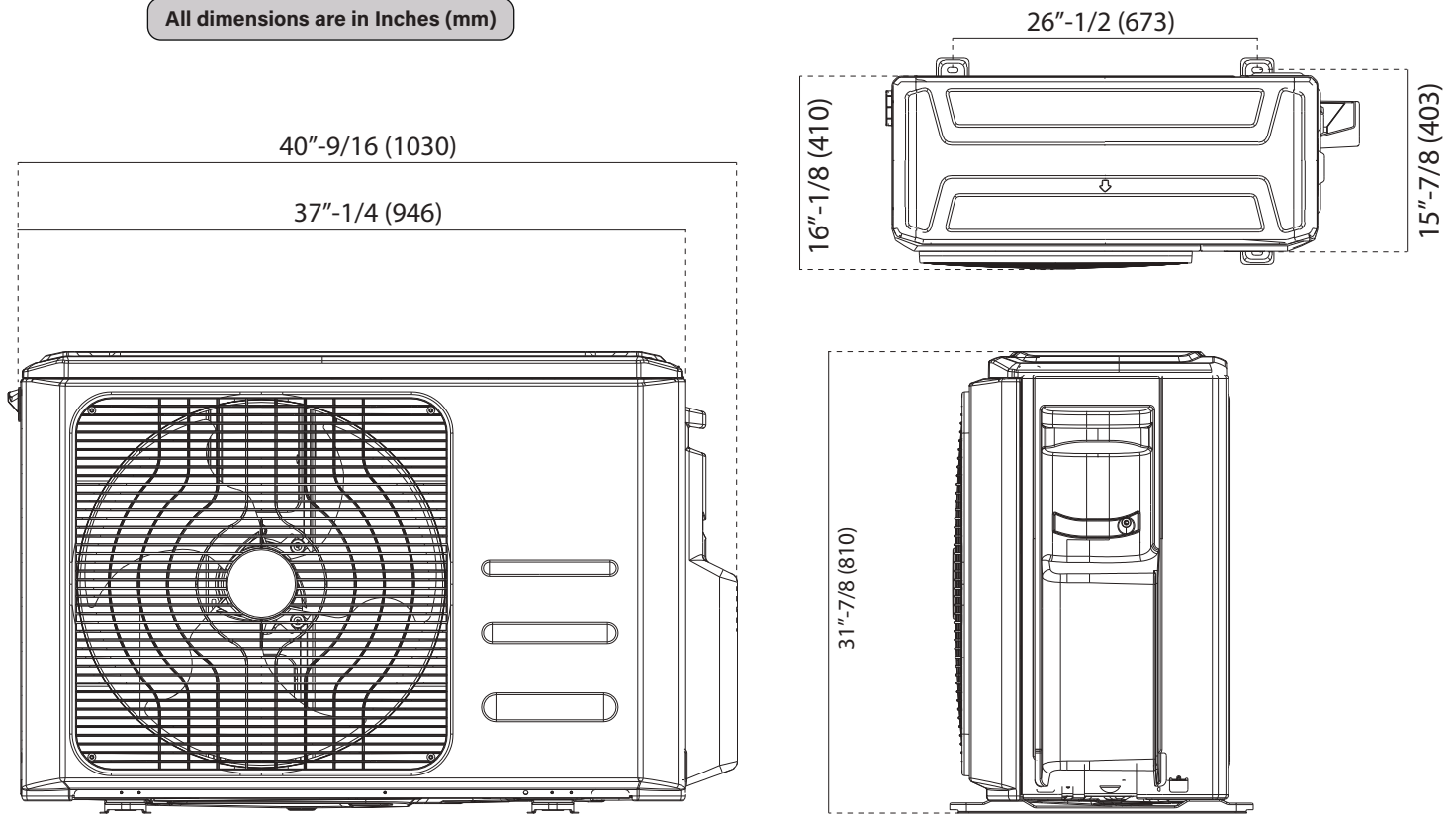

Warranty Information and Length



Complete warranty details are available with the vendor or online at <https://www.pdhvac.com/support/warranty/>. This high quality system is eligible for up to **5** years limited warranty on the compressor, and **5** years on other internal parts. To qualify for this warranty, the system must be installed within 90 days and registered properly. All other installations that are unregistered qualify for only **1** year parts/compressor warranty.

Outstanding Features

- Minimalist Design + Quiet Operation
- Two-Way Installation (Ceiling/Floor)
- Optional Programmable Controller
- Multiple Lineset Hookup Options
- 3D Airflow (Vertical + Horizontal)
- Washable Re-usable Filter
- Dual Drainage Locations
- Fresh Air Intake Port

Available Accessories

Part Number	Description
IKT-LCVR4P-KIT	<i>Decorative PVC Line Cover Kit</i>
TST-LCACWIFIKP	<i>Smart-WiFi Wired Wall Thermostat Kit</i>
BRK-FRM-C-2P	<i>Folding Mounting Bracket w/ Leveler</i>
IKT-UVL32UL-AG	<i>UVC Bacterial Disinfection Kit</i>
@ICM517	<i>Ultimate Surge and Power Protection</i>