

OWNER'S MANUAL

Ceiling - Floor Type Ductless Split Systems

UB018 - UB024 - UB036 - UB048 Indoor Units
UYB018 - UYB024 - UYB036 - UYB048 System Sets



PIONEER®

Thank you for your purchase of this air conditioner.
Before attempting to use your air conditioner, please read this manual carefully and store it for future reference.

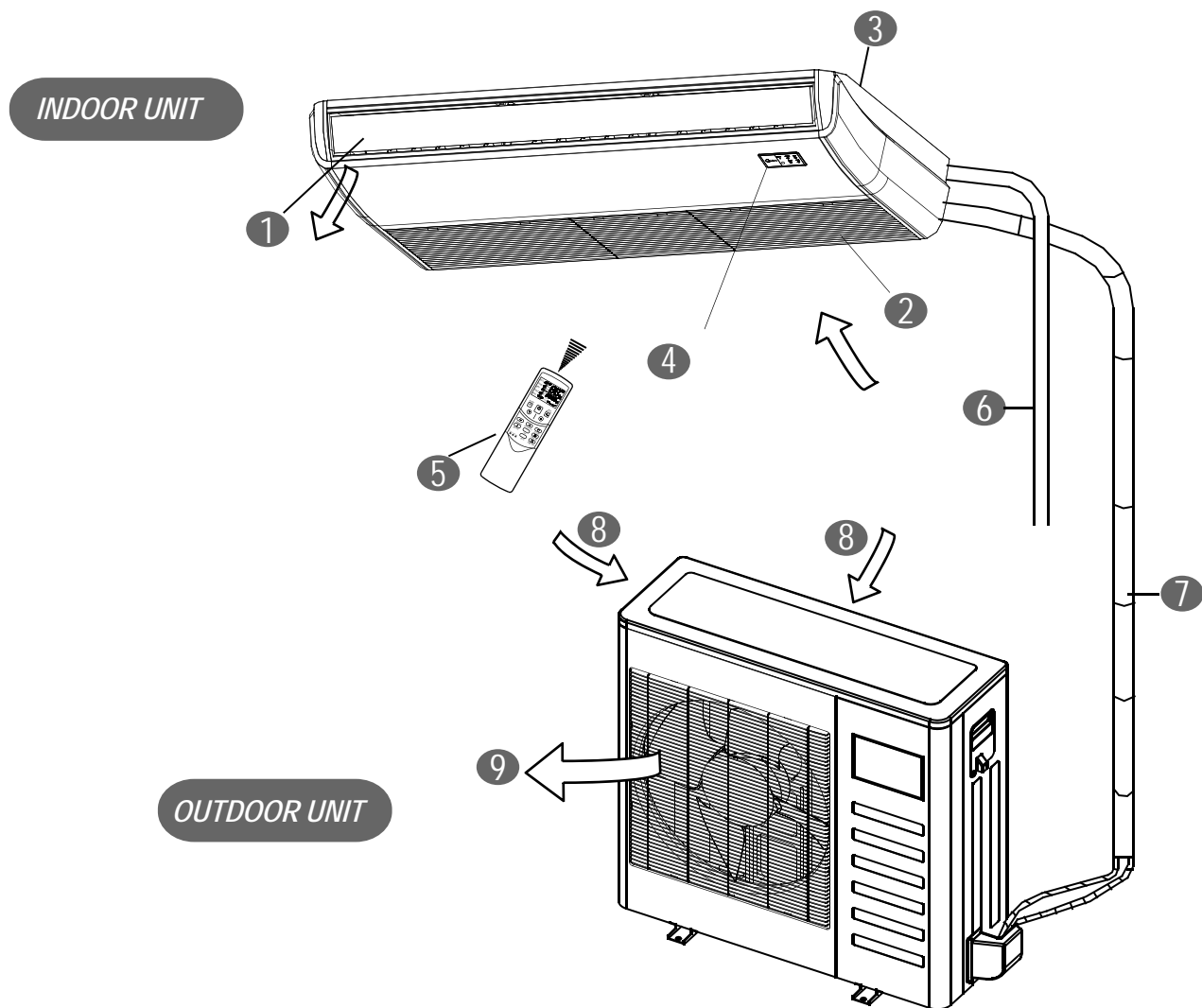

INDOOR UNIT

OUTDOOR UNIT

INDOOR UNIT

- ① Air Flow Louver (at Air Outlet)
- ② Air Inlet (and Air Filter within)
- ③ Installation Section
- ④ Display Panel
- ⑤ Remote Controller
- ⑥ Drain Pipe

OUTDOOR UNIT

- ⑦ Connecting Pipe
- ⑧ Air Inlet
- ⑨ Air Outlet

Fig.1



NOTE

All graphics in this manual are for explanatory purposes only. There may be slight differences from the air conditioner that you purchased (dependent on model). The actual shape shall prevail.

CONTENTS

PAGE

IMPORTANT SAFETY INFORMATION.....	1
TEMPORARY OPERATIONS.....	2
AIR CONDITIONER OPERATIONS AND PERFORMANCE.....	3
HINTS FOR ECONOMICAL OPERATION.....	4
ADJUSTING AIR FLOW DIRECTION.....	4
MAINTENANCE.....	4
THESE SYMPTOMS ARE NOT AIR CONDITIONER TROUBLES.....	5
TROUBLESHOOTING.....	6

1. IMPORTANT SAFETY INFORMATION

To prevent injury to the user or other persons, as well as property damage, the following instructions must be followed. Incorrect operation due to ignorance of instructions may cause product damage or personal harm.

The safety precautions listed below are divided into two categories. In either case, important safety information is given and must be read carefully and complied with.



WARNING

The appliance shall be installed in accordance with national wiring regulations. Failure to observe a warning may result in severe injury and/or death.



CAUTION

Failure to observe a caution may result in injury or damage to the equipment.



WARNING

Consult your dealer for installation of the air conditioner.
Incomplete installation performed by yourself may result in a water leakage, electric shock, or fire.

Ask your dealer for methods of improvement, repair, and maintenance.
Improper improvement, repair, and maintenance may result in a water leakage, electric shock, and fire.

In order to avoid electric shock, fire or injury, or if you detect any abnormality such as fire odors, turn off the power supply and call your dealer for more instructions.

Never let the indoor unit or the remote controller get wet.
It may cause an electric shock or a fire.

Never press the button of the remote controller with a hard, pointed object.
The remote controller may be damaged.

Never replace a fuse with that of an incorrectly rated current, or other wires, when a fuse blows out.
Use of wire or copper fuses may cause the unit to break down, or cause a fire.

It is not good for your health to expose your body to the air flow for a prolonged period of time.

Do not insert fingers, rods, or other objects into the air inlet or outlet.
When the fan is rotating at a high speed, it can cause injury.

Never use a flammable spray, such as hair spray, lacquer, or paint near the unit.
It may cause a fire.

Never touch the air outlet, or the horizontal blades, while the swing flap is in operation.
Fingers may become caught within, or the unit may break.

Never put any objects into the air inlet or outlet.
Objects coming into contact with the high speed fan can become dangerous.

Never inspect or service the unit by yourself.
Ask a qualified service person to perform this work.

Do not dispose of this product as unsorted municipal waste. Separate collection of such waste for special treatment is necessary.

Do not dispose of electrical appliances as unsorted municipal waste. Use separate collection facilities.
Contact your local government for information regarding the collection systems available.

If electrical appliances are disposed of in landfills or dumps, hazardous substances can eventually leak into the groundwater and get into the food chain, damaging your health and well-being.

To prevent refrigerant leak, contact your dealer.
When the system is installed and runs in a small room, it is required to keep the concentration of the refrigerant, if by any chance it leaks, below the limit. Otherwise, oxygen in the room may be affected, resulting in a serious hazard.

The refrigerant in the air conditioner is safe and normally does not leak.
If the refrigerant leaks inside the room, contact with fire from a burner, heater, or cooker may result in harmful gas. Turn off any combustible heating devices, ventilate the room, and contact the dealer from where you purchased the unit. Do not use the air conditioner until a service person confirms that the segment from where the refrigerant leaks is repaired.



CAUTION

Do not use the air conditioner for abnormal purposes.
In order to avoid any quality degradation, do not use the unit for cooling of precision instruments, food, plants, animals, or works of art.

Before cleaning, be sure to cease operation and turn the breaker off or pull out the supply cord.
Otherwise, an electrical shock and possible injury may result.

In order to avoid electric shock or fire, ensure that an earth leak detector is installed.

Be sure that the air conditioner is grounded.
In order to avoid electric shock, make sure that the unit is grounded and that the earth wire is not connected to a gas or water pipe, lightning conductor, or telephone earth wire.

In order to avoid injury, do not remove the fan guard of the outdoor unit.

Do not operate the air conditioner with wet hands.
An electric shock may occur.

Do not touch the heat exchanger fins.
These fins are sharp and could result in cutting injuries.

Do not place items which might be damaged by moisture underneath the indoor unit.
Condensation may form if the humidity is above 80%, the drain outlet is blocked, or the filter is polluted.

After extended use, check the unit stand and fitting for damage.
If the stand is damaged, the unit may fall and result in injury.

To avoid the risk of oxygen deficiency, ventilate the room sufficiently if any equipment with a burner is used together with the air conditioner.

Arrange the drain hose to ensure smooth drainage.
Incomplete drainage may cause wetting of the building, furniture, etc.

Never touch the internal parts of the controller.
Do not remove the front panel. Some parts inside are dangerous to touch, and machine trouble may happen.

Never expose little children, plants, or animals directly to the air flow.
Adverse harmful effects to little children, animals, and plants may result.

Do not allow children to climb onto the outdoor unit, or to place an object on top of it.
Falling or tumbling may result in injury.

Do not operate the air conditioner when using room fumigation-type insecticide.
Failure to observe this precaution could cause the chemicals to become deposited in the unit, which could endanger the health of those who are hypersensitive to chemicals.

Do not place appliances which produce open fire in places exposed to the air flow from the unit, or under the indoor unit.
It may cause incomplete combustion, or deformation of the unit, due to the heat.

Do not install the air conditioner in any place where flammable gas may leak out.
If the gas leaks out and stays around the air conditioner, a fire may break out.

The appliance is not intended for use by young children or infirm persons without supervision.

This appliance can be used by children aged from 8 years and above, along with persons with reduced physical, sensory or mental capabilities, or lack of experience and knowledge, if they have been given supervision or instruction concerning use of the appliance in a safe way, and understand the hazards involved. Children shall not play with the appliance. Cleaning and user maintenance shall not be made by children without supervision.

This appliance is not intended for use by persons (including children) with reduced physical, sensory, or mental capabilities, or lack of proper experience and knowledge, unless they have been given supervision or instruction concerning use of the appliance, by a person responsible for their safety.

Children should be supervised to ensure that they do not play with the appliance.

If the supply cord is damaged, it must be replaced by the manufacturer, its service agent, or similarly qualified persons, in order to avoid a hazard.

Do not operate your air conditioner in a wet room, such as a bathroom or laundry room.

2. TEMPORARY OPERATIONS

The air conditioner consists of the indoor unit, the outdoor unit, the connecting pipe and the remote controller. (See Fig. 1)

■ Function Indicators on Indoor Unit Display Panel

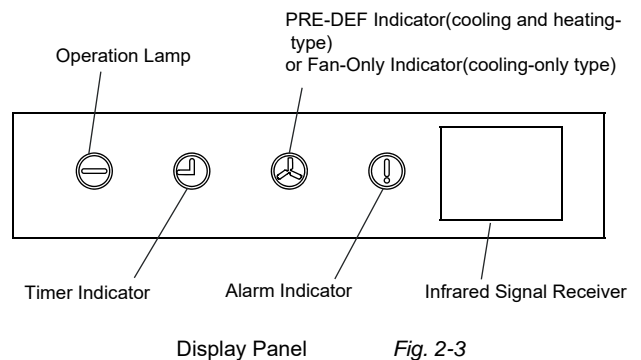
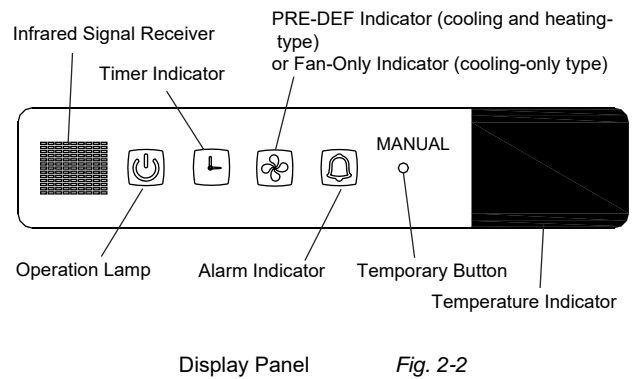
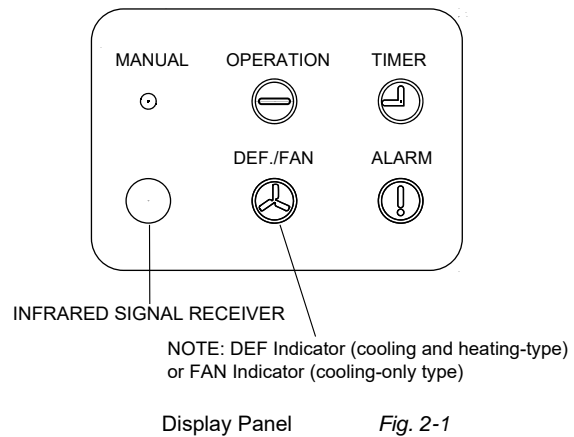

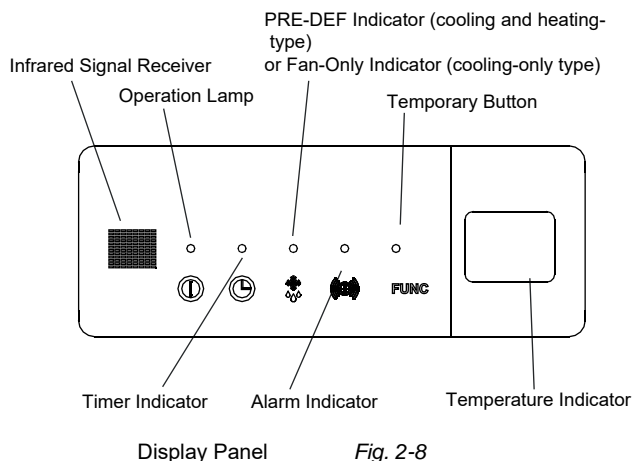
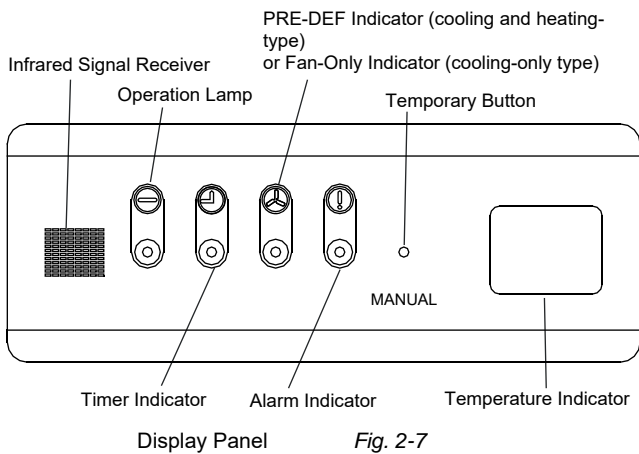
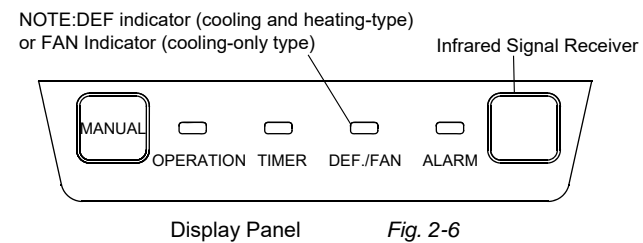
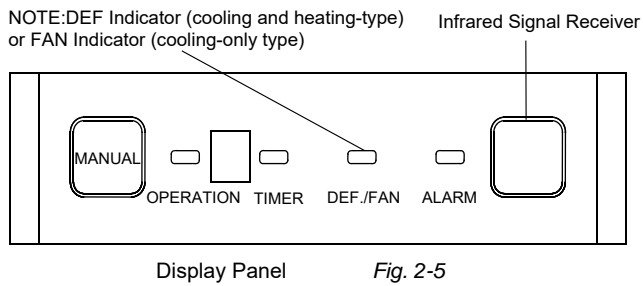
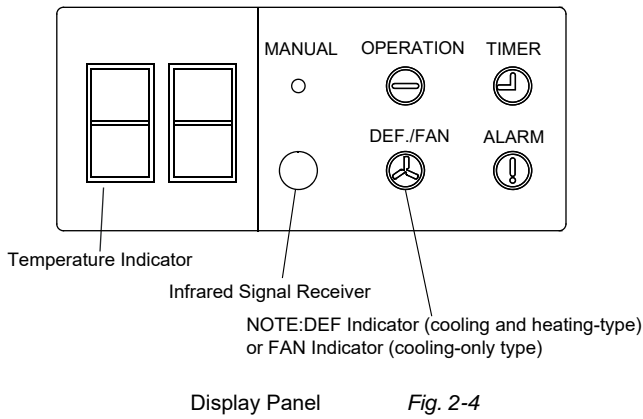

For the inverter type, this switch is used for after-sales service purposes only. Users should not touch it.

For the fixed-frequency type, this function is used to operate the unit temporarily, the remote controller is misplaced, or its batteries have been exhausted. Two modes, including FORCED AUTO and FORCED COOL, can be selected through the TEMPORARY BUTTON on the air-in grill control box of the indoor unit. Once you push this button, the air conditioner will run in the following order: FORCED AUTO, FORCED COOL, OFF, and back to FORCED AUTO.

- 1 FORCED AUTO
The OPERATION lamp is lit, and the air conditioner will run under FORCED AUTO mode. The remote controller operation is enabled to function according to the received signal.
- 2 FORCED COOL
The OPERATION lamp flashes, the air conditioner will turn to FORCED AUTO after it is set to cool with a wind speed of HIGH for 30 minutes. The remote controller operation is disabled.
- OFF
- 3 The OPERATION lamp goes off. The air conditioner is OFF, while the remote controller operation is enabled.



NOTE

This manual does not include Remote Controller Operations, see the "Remote Controller Owner's manual", which is packed with the unit, for further details.

3. AIR CONDITIONER OPERATIONS AND PERFORMANCE

Use the system with the following temperatures for safe and effective operation. The max operation temperatures for the air conditioner is listed. (Cooling/Heating)

Table 3-1

Mode	Temperature	
	Outdoor Temperature	Room Temperature
Cooling Operation	0°C ~ 50°C / 32 °F~122°F	17°C ~ 32°C (62 °F ~ 90°F)
	-15°C ~ 50°C / 5 °F~122°F (for the models with low temperature cooling system)	
Heating Operation (Inverter++ Models)	-25°C ~ 24°C / -12 °F~76°F	0°C ~ 30°C / 32 °F~86°F
Drying Operation	0°C ~ 50°C / 32 °F~122°F	17°C ~ 32°C (62 °F ~ 90°F)



NOTE

- 1 If the air conditioner is used outside the above conditions, it may cause the unit to function abnormally.
- 2 The phenomenon of when the surface of the air conditioning unit condenses with water is normal when there is a larger relative humidity in room. Please close doors and windows.
- 3 Optimal performance will be only be achieved when within these operating temperature ranges.

■ Three-Minute Protection Feature

A protection feature prevents the air conditioner from being activated for approximately 3 minutes, when it restarts immediately after operation.

■ Power failure

Power failure during operation will stop the unit completely.

- The OPERATION lamp on the indoor unit will start flashing when the power is restored
- To restart operation, push the ON/OFF button on the remote controller.
- Lightning or wireless telephones operating nearby may cause the unit to malfunction.

Disconnect the unit from the power, and then reconnect the unit to the power again. Push the ON/OFF button on the remote controller to restart operation.

■ Refrigerant Leakage Detection (optional):

With this new technology, the display area will show EC ' (if applicable), and the LED indication lamps will continue flashing when the outdoor unit detects refrigerant leakage.

■ Louver Angle Memory Function (optional):

For some models, the machine is specially designed with a louver angle memory function. Power failure during operation, or pressing the ON/OFF button on the remote controller, will stop the unit completely. When the power restores, or by pressing the ON/OFF button on the remote controller again, the unit restarts automatically with the previous open angle of the horizontal louver set by the memory function. Hence, we strongly recommend that the open angle of the horizontal louver should not be set to be too small, in case condensed water forms and drops from the horizontal louver. By pressing the manual control button, the open angle of the horizontal louver will be restored to the standard angle.

4. HINTS FOR ECONOMICAL OPERATION

The following should be adhered to in order to ensure fully optimal performance. (Refer to corresponding chapters for details)

- Adjust the air flow direction properly to avoid direct draft toward your body.
- Adjust the room temperature properly to get a comfortable environment and to also avoid supercooling and superheating.
- During cooling, close the curtains to avoid direct sunlight.
- To keep cool or warm air in the room, never open doors or windows more often than when necessary.
- Set the timer for the desired operating time.
- Never put obstructions near the air outlet or the air inlet. Else it will cause lowered efficiency, or even a sudden stop.
- If you don't plan to use the unit for a long time, disconnect the power and remove the batteries from the remote controller. When the power switch is connected, some energy will be consumed, even if the air conditioner isn't in operation. Disconnect the power to save energy. Also, switch the power on 12 hours before you restart the unit to ensure a smooth operation.
- A clogged air filter will reduce cooling or heating efficiency, therefore it's important to clean it once every two weeks.

5. ADJUSTING AIR FLOW DIRECTION

5.1 Adjust the horizontal louver

Auto-swing

Press the SWING button, and the louver will swing up and down automatically.

Manual Swing

Adjust the louver to your desired angle to achieve better cooling/heating effects when cooling /heating.

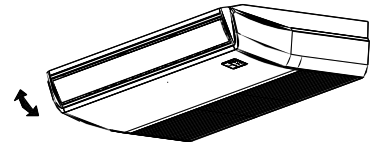

Fig. 5-1

When cooling

Adjust the louver horizontally.

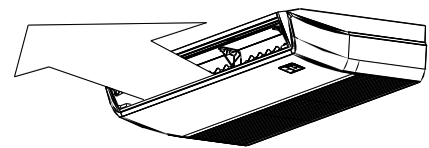

Fig. 5-2

When heating

Adjust the louver downwards. (vertically)

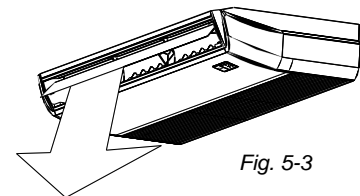

Fig. 5-3

5.2 Adjust the Vertical louver

Auto-swing

Press the SWING H button, and the louver will swing left and right automatically.

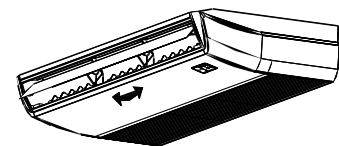

Fig. 5-4

6. MAINTENANCE



CAUTION

Before you clean the air conditioner, be sure the power supply is off.

Check that the wiring is not broken off or disconnected.

Use a dry cloth to wipe the indoor unit and remote controller.

A wet cloth may be used to clean the indoor unit if it is very dirty.

Never use a damp cloth on the remote controller.

Do not use a chemically-treated duster for wiping, or leave any such material on the unit for long, as it may damage or cause fading on the surface of the unit.

Do not use benzene, paint thinner, polishing powder, or similar solvents for cleaning.

■ Maintenance After a Long Break Period

(e.g. at the beginning of the season)

Check and remove everything that might be blocking inlet and outlet vents on the indoor units and outdoor units.

Clean the air filters and casings of indoor units. Refer to "Cleaning the Air Filter" for details on how to proceed, and make sure to install cleaned air filters back to the same position.

Turn on the power at least 12 hours before operating the unit, in order to ensure smoother operation. As soon as the power is turned on, the remote controller displays appear.

■ Maintenance before a Long Stop Period

(e.g. at the end of the season)

Let the indoor units run in fan only operation for about half a day in order to dry the interior of the units.

Clean the air filters and casings of the indoor units. Refer to "Cleaning the Air Filter" for details on how to proceed, and make sure to install cleaned air filters back to the same position.

■ Cleaning the Air Filter

The air filter can prevent dust or other particles from going inside. In the case of blockage of the filter, the working efficiency of the air conditioner may drastically decrease. Therefore, the filter must be cleaned once every two weeks during long time usage.

If the air conditioner is installed in a dusty place, clean the air filter frequently.

If the accumulated dust is too heavy to be cleaned, please replace the filter with a new one (a replaceable air filter is an optional fitting).

All filter cleaning should be performed by a suitable handyperson.

1 3.2-10.5KW

- Open the air intake with a screwdriver or similar tool. (Refer to Fig. 6-1)
- Remove the air filter. (Refer to Fig. 6-2)
- Clean the air filter with water or a vacuum cleaner, then dry it in a cool place.
- Re-install the air filter in the reverse order of Fig. 6-2.

2 14-16KW

- Directly pull out the air filter from the air inlet as indicated in Fig. 6-3.
- Clean the air filter with water or a vacuum cleaner, then dry it in a cool place.
- Re-install the air filter in the reverse order of Fig. 6-3.



NOTE

- The air-in side should face up when using a vacuum cleaner.
- The air-in side should face down when using water.



CAUTION

Do not dry out the air filter underneath direct sunshine.

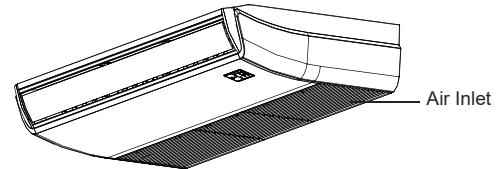

Fig.6-1

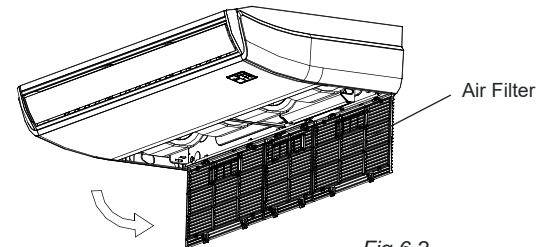

Fig.6-2

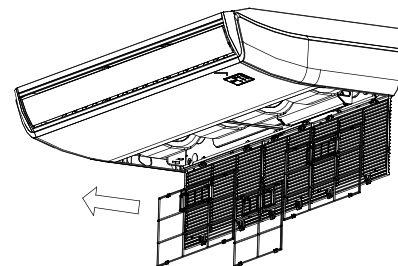

Fig.6-3

7. THE FOLLOWING SYMPTOMS ARE NOT AIR CONDITIONER TROUBLES

Symptom 1: System does not operate

- The air conditioner fails to start immediately after the ON/OFF button on the remote controller is pressed. If the operation lamp lights up, then the system is in normal condition. To prevent overloading of the compressor motor, the air conditioner starts 3 minutes after it is turned ON.
- If the operation lamp and the "PRE-DEF" indicator (cooling and heating type) or "Fan-Only" indicator (cooling-only type) lights up, it means that you chose heating mode. When just booting, if the compressor has not started, the indoor unit appears as "anti cold wind" protection, due to overflow outlet temperature.

Symptom 2: System switches to Fan Mode during Cooling Mode

- In order to prevent indoor evaporator frosting, the system will switch to fan mode automatically, and will restore back to cooling mode shortly after.
- When the room temperature drops to the set temperature, the compressor goes off, and the indoor unit changes to fan mode. When the temperature rises up, the compressor starts again. It works the same way in heating mode.

Symptom 3: White mist comes out of a Unit

Symptom 3.1: Indoor Unit

- When humidity is high during a cooling operation, and if the interior of an indoor unit is extremely dirtied, the temperature distribution inside a room becomes uneven. It is necessary to clean the interior of the indoor unit. Ask your dealer for details on cleaning the unit. This operation requires qualified service personnel.

Symptom 3.2: Indoor Unit, Outdoor Unit

- When the system is switched over to a heating operation after a defrosting operation, any moisture generated by defrosting becomes steam, and is emitted outward.

Symptom 4: Noise of Air Conditioners cooling

Symptom 4.1: Indoor Unit

- *A continuous and low hissing sound is heard when the system is in a cooling operation, or at a stop.*
When the drain pump (optional accessory) is in operation, this noise is also heard.
- *A "pss-pss" squeaking sound is heard when the system stops after completion of a heating operation.*
Expansion and contraction of plastic parts caused by temperature changes also make this noise.

Symptom 4.2: Indoor Unit, Outdoor Unit

- *A continuous low hissing noise is heard when the system is in operation.*
This is the sound of refrigerant gas flowing through both the indoor and outdoor units.
- *A hissing sound is heard at the start, or immediately after, stopping operation, or beginning a defrosting operation.*
This is the noise of refrigerant, caused by flow stoppage or flow change.

Symptom 4.3: Outdoor Unit

- *When the tone of operating noise changes.*
This noise is caused by a change of frequency.

Symptom 5: Dust comes out of the Unit

- *When the unit is used for the first time in a long time.*
This is most likely due to dust having gotten inside the unit.

Symptom 6: The Unit gives off strange odors

- The unit can absorb the smell of rooms, furniture, cigarettes, etc., and then emit it again.

Symptom 7: The Outdoor Unit fan does not spin.

- During operation, the speed of the fan is controlled in order to optimize product operation.

8. TROUBLESHOOTING

9.1. Malfunctions of the Air Conditioner

If one of the following malfunctions occur, cease operation, shut off the power, and contact your dealer.

- The operation lamp is flashing rapidly (~5Hz) and the lamp continues flashing rapidly after turning off the power and turning it on again. (Refer to Table 9-1)
- Remote controller starts malfunctioning or the buttons do not work well.
- A safety device, such as a fuse or breaker, frequently actuates.
- Obstacles and/or water enter the unit.
- Water leaks out of the indoor unit.
- Any other strange, concerning malfunctions.

If the system does not properly operate, except when the above mentioned cases or the above mentioned malfunctions is evident, investigate the system according to the following procedures. (Refer to Table 9-2).

Table 8-1

NO.	Malfunction	display (nixie tube)	timer lamp	running lamp (flashes per second)
1	Indoor EEPROM error	E0	OFF	1
2	Communication malfunction between indoor and outdoor units	E1	OFF	2
3	Indoor fan speed malfunction	E3	OFF	4
4	Indoor room temperature sensor open circuit or short circuit	E4	OFF	5
5	Evaporator coil temperature sensor open circuit or short circuit	E5	OFF	6
6	Refrigerant leakage detection malfunction	EC	OFF	7
7	Water-level alarm malfunction	EE	OFF	8
8	Communication malfunction between two indoor units (for twins model)	E8	OFF	9
9	Other malfunction of twins model	E9	OFF	10
10	Current overload protection	F0	ON	1
11	Outdoor room temperature sensor open circuit or short circuit	F1	ON	2
12	Outdoor condenser pipe temperature sensor error	F2	ON	3
13	Discharging air temperature sensor error	F3	ON	4
14	Outdoor EEPROM error	F4	ON	5
15	Outdoor fan speed malfunction (Only for DC fan motor)	F5	ON	6
16	T2b sensor error	F6	ON	7
17	Inverter module IPM protection	P0	Flash	1
18	High/Low voltage protection	P1	Flash	2
19	High temperature protection of compressor top	P2	Flash	3
20	Outdoor low temp. protection	P3	Flash	4
21	Compressor drive error	P4	Flash	5
22	Mode conflict	P5	Flash	6

Table 8-2

Symptoms	Causes	Solution
Unit does not start	<ul style="list-style-type: none"> • Power failure. • Power switch is off. • Fuse of power switch may have burned. • Batteries of remote controller exhausted or other problem of controller. 	<ul style="list-style-type: none"> • Wait for the return of power. • Switch on the power. • Replace the fuse. • Replace the batteries, or check the controller.
The air is flowing normally but can't completely cool	<ul style="list-style-type: none"> • Temperature is not set correctly. • Possible 3 minute protection precaution of compressor. 	<ul style="list-style-type: none"> • Set the temperature properly. • Wait 3 minutes and try again.
Units start or stop frequently	<ul style="list-style-type: none"> • Refrigerant is too little or too much. • Air or no concretingc gas in the refrigerating circuit. • Compressor is malfunction. • Voltage is too high or too low. • System circuit is blocked. 	<ul style="list-style-type: none"> • Check leakage, and rightly recharge refrigerant. • Vacuum and recharge refrigerant. • Maintenance or change compressor. • Install manostat. • Find reasons and solution.
Insufficient cooling results	<ul style="list-style-type: none"> • Outdoor unit and/or indoor unit heat exchanger is dirty. • The air filter is dirty. • Inlet/outlet of indoor/outdoor units has blockage. • Doors and windows are open. • Sunlight is shine directly onto unit. • Too many heat sources within the area. • Outdoor temp. is too high. • Leakage of refrigerant, or lack of refrigerant. 	<ul style="list-style-type: none"> • Clean the heat exchanger. • Clean the air filter. • Eliminate all contaminants and make filtrate the air. • Close doors and windows. • Draw curtains closed in order to shield from sunshine. • Reduce heat source. • A/C cooling capacity is reduced (normal). • Check leakage and recharge refrigerant.
Low heating effect	<ul style="list-style-type: none"> • Outdoor temperature is lower than 7 C° • Doors and windows not completely closed. • Leakage of refrigerant, or lack of refrigerant. 	<ul style="list-style-type: none"> • Use heating device. • Close doors and windows. • Check leakage and recharge refrigerant.

9.2 Malfunctions of Remote Controller

Before asking for serving or repairing, please check the relevant points.

Symptoms	Causes	Solution
The fan speed can not be changed.	<ul style="list-style-type: none"> Check whether the MODE indicated on the display is "AUTO" 	When the automatic mode is selected, the air conditioner will automatically change the fan speed.
	<ul style="list-style-type: none"> Check whether the MODE indicated on the display is "DRY" 	When dry operation is selected, the air conditioner automatically change the fan speed. The fan speed can be selected during "COOL" , "FAN ONLY", and "HEAT".
The remote controller signal is not transmitted even when the ON/OFF button is pushed.	<ul style="list-style-type: none"> Check whether the batteries in the remote controller are exhausted. 	The power supply is off.
The TEMP. indicator does not come on.	<ul style="list-style-type: none"> Check whether the MODE indicated on the display is FAN ONLY 	The temperature cannot be set during FAN mode.
The indication on the display disappears after a lapse of time.	<ul style="list-style-type: none"> Check whether the timer operation has come to an end when the TIMER OFF is indicated on the display. 	The air conditioner operation will stop up to the set time.
The TIMER ON indicator goes off after a lapse of certain time.	<ul style="list-style-type: none"> Check whether the timer operation is started when the TIMER ON is indicated on the display. 	Up to the set time, the air conditioner will automatically start and the appropriate indicator will go off.
No receiving tone sounds from the indoor unit even when the ON/OFF button is pressed.	<ul style="list-style-type: none"> Check whether the signal transmitter of the remote controller is properly directed to the infrared signal receiver of the indoor unit when the ON/OFF button is pressed. 	Directly transmit the signal transmitter of the remote controller to the infrared signal receiver of the indoor unit, and then repeatedly push the ON/OFF button twice.